

OPERATION MANUAL

CLIMATE PRO 12

Unit Serial Number Range: 0915XXXXH12 to Present
(From September 2015 to Present)



**READ THIS MANUAL CAREFULLY FOR INSTRUCTIONS ON CORRECT
INSTALLATION AND USAGE, AND READ ALL SAFEGUARDS**

SECCIÓN EN ESPAÑOL
SECTION EN FRANÇAIS
AVAILABLE AT WWW.MOVINCOOL.COM



MOVINCOOL®
THE #1 SPOT COOLING SOLUTION

SERIAL NUMBER LOCATION AND IDENTIFICATION

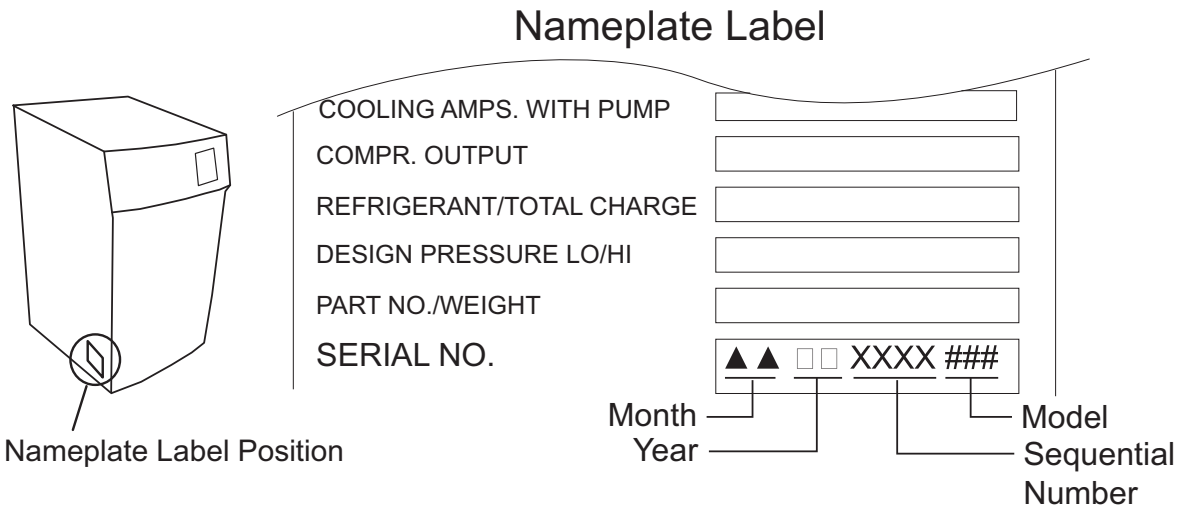

© 2015 DENSO PRODUCTS AND SERVICES AMERICAS, INC.
All rights reserved. This book may not be reproduced or copied, in whole or in part, without the written permission of the publisher. DENSO PRODUCTS AND SERVICES AMERICAS, INC. reserves the right to make changes without prior notice. MovinCool®, Office Pro®, and SpotCool® are registered trademarks of DENSO Corporation.

OPERATION MANUAL

CLIMATE PRO 12

MOVINCOOL[®]
THE #1 SPOT COOLING SOLUTION

Table of Contents

SERIAL NUMBER LOCATION AND IDENTIFICATION	2
FOREWORD	6
Definition of Terms	6
GENERAL WARNINGS & CAUTIONS	7
INVENTORY	8
INSTALLATION	9
Choosing an Installation Site	9
Moving the Unit	10
Setup Configuration and Accessories	11
Plugging in the Unit	12
LCDI Power Cord Instruction	13
Test Procedure	13
External Thermostat Connection	14
External Millivolt Thermostat Connection (Optional Accessory)....	14
External 24VAC Thermostat Connection (Field Supplied)	16
External Warning Device Connection	17
External Alarm Device Connection	19
FEATURES	21
OPERATION	22
Operation Modes	22
Control Panel	23
LCD Indicators	24
Set Clock	25
Cool Mode Operation	26
Heat Mode Operation	27
Fan Only Mode Operation	28
Menu Features	29
Key Lock and Unlock	29
Fan Mode Control	30
LCD Brightness Adjustment	30
Changing Temperature Scale	31
Activating External Thermostat	31
Program Operation and Schedule	32
Setting Program	32
Viewing Program	33
Clearing All Programs Slots	33
Clearing Each Program Slot	34
Starting Program Operation	35
Stopping Program Operation	36
Self-Diagnostic Codes	37
Emptying the Drain Tank	40

Condensate Pump Kit (Optional Accessory) 41

DAILY MAINTENANCE 42

 Emptying the Drain Tank 42

 Air Filter Maintenance 42

 Removing the Air Filters 42

 Cleaning the Air Filters 42

SEASONAL MAINTENANCE 43

 In-Season 43

 Off-Season 43

TROUBLESHOOTING 44

TECHNICAL SPECIFICATIONS 47

WARRANTY STATEMENT 49

FOREWORD

Congratulations on purchasing the MovinCool portable air conditioner. This manual explains how to install and operate the MovinCool Climate Pro 12 portable air conditioning unit. Please read this operation manual thoroughly to familiarize yourself with the features of the unit and to ensure years of reliable operation.

You may also find it useful to keep this operation manual on hand for reference. Components and/or procedures are subject to change without prior notice.

Definition of Terms

 **WARNING:** Describes precautions that should be observed in order to prevent injury to the user during installation or unit operation.

 **CAUTION:** Describes precautions that should be observed in order to prevent damage to the unit or its components, which may occur during installation or unit operation if sufficient care is not taken.

Note: Provides additional information that facilitates installation or unit operation.

GENERAL WARNINGS & CAUTIONS

- All electrical work must be performed by qualified electrical personnel. Repair to electrical components by non-certified technicians may result in personal injury and/or damage to this unit. All electrical components replaced must be genuine MovinCool parts, purchased from an authorized dealer.
- The power source for this unit should be a dedicated single outlet circuit with UL recognized short-circuit and ground fault protective breaker.
- Because of potential safety hazards under a certain condition, we strongly recommend against the use of an extension cord. However, if you still elect to use an extension cord, it is absolutely necessary that it is a UL listed, 3-wire grounding type appliance extension cord, having a 3-blade and a 3-slot receptacle that plugs into the appliance. The marked rating of the extension cord should be 125 V, 15 A or equivalent.
- This unit is equipped with a 10 feet (3.0 m) UL recognized LCDI power cord. If replacement, fixed location (hard wired) or power cord lengthening (extension cord) is required, contact your dealer or a qualified electrician for approved methods.
- Never fold or place heavy objects on the power cord. This could result in damage to the power cord causing electrical shock or fire.
- Turn this unit off and unplug the power cord when the power cord is damaged.
- Do not place water or any other liquid on this unit. This can cause damage to the unit and increase the risk of electrical shock.
- Do not use water to clean inside this unit. Exposure to water can destroy the insulation and electrical components, leading to electric shock.
- Interior cleaning of this unit must be performed by authorized personnel only. Consult your MovinCool dealer.
- Do not sit or stand on this unit.

INVENTORY

After unpacking your MovinCool unit, please check to make sure you have the following items:

- 1. Climate Pro 12 Unit (1)
- 2. Operation Manual (1)
- 3. Product Registration (1)

Note: If any of these items were not included in the box or appear damaged, please contact your MovinCool dealer for replacement.

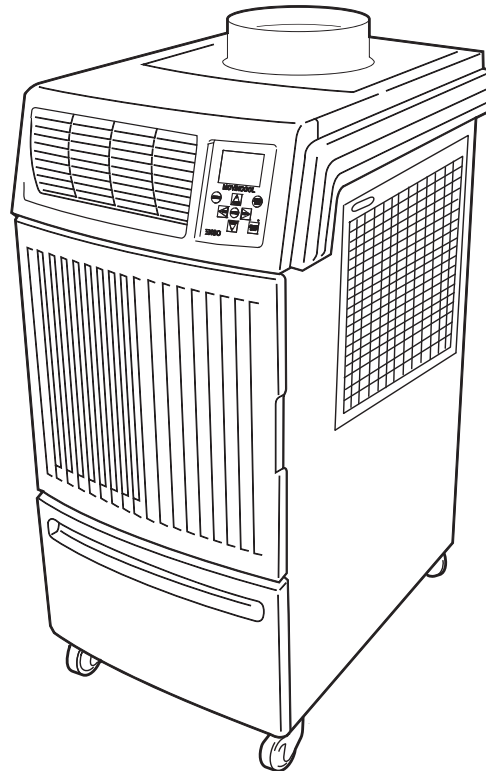

Climate Pro 12 Unit

ILL00961-00

Product Registration



Operation Manual

ILL00042-02

INSTALLATION

Choosing an Installation Site

 **CAUTION: Following are some precautions to consider before choosing your installation site. Please review carefully as improper installation may result in personal injury or damage to the unit.**

- Do not use the unit in areas where leakage of flammable gas may occur.
- Do not use the unit in areas where it is exposed to rain or water.
- Do not use the unit in an environment which contains excessive amounts of corrosive gas or vapor.
- Do not use in areas where the temperature is outside the allowable operating range.
- Do not install the unit in sloping areas. The unit may move or topple over even if the casters are set to the LOCKED position.
- Install the unit in areas where can withstand the weight of the unit.

Model	Unit Weight ^{*1}
Climate Pro 12	249 lb (113 kg)

*1: Approximate weight when the drain tank is full of water.

- Allow 24 inch (610 mm) of unobstructed airflow for both the air inlets and outlets.

INSTALLATION (cont.)

Moving the Unit

Unlock the casters and push the unit using the side handles to a flat, level surface and set the casters back to the LOCKED position.

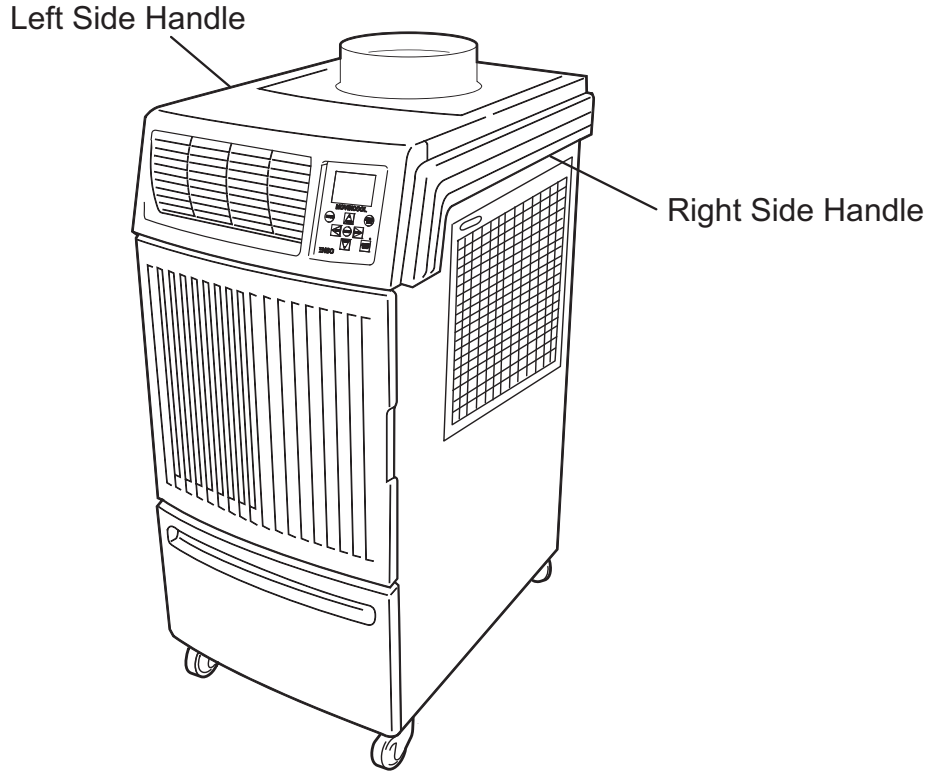

ILL00962-00

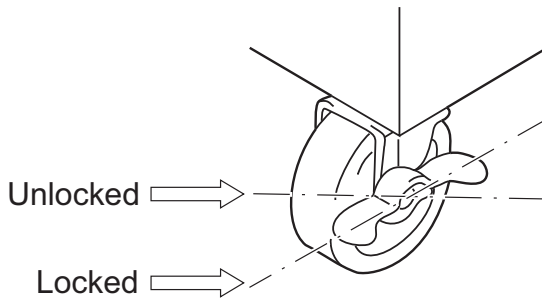

ILL00044-01

INSTALLATION (cont.)

Setup Configuration and Accessories

The Climate Pro 12 works more efficiently with optional accessories set up and configured for cooling and heating application. The most common setup configurations are:

1. Spot Cooling/Heating Configuration

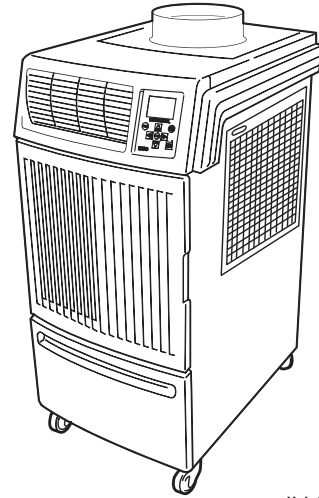

ILL00963-00

2. Single Duct Cooling/Heating Configuration

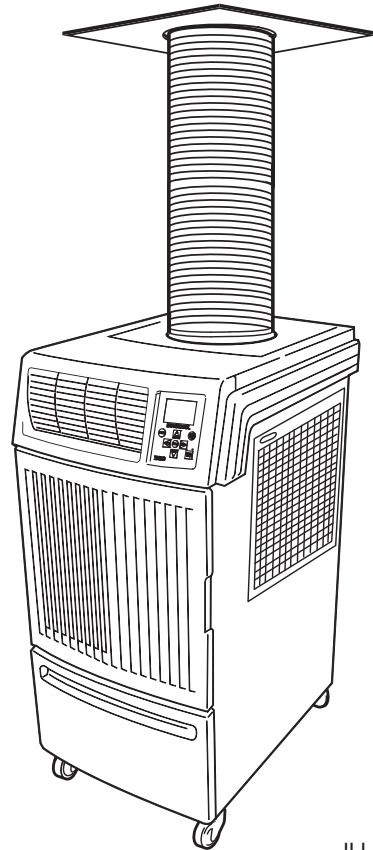

ILL00964-00

INSTALLATION (cont.)

Plugging in the Unit

1. Check the prongs and surface of the power cord plug for dust/dirt. If dust and/or dirt are present, wipe off with a clean, dry cloth.
2. Check the power cord, plug and prongs for damage or excess play. If any damage or excess play is found, contact your MovinCool dealer for replacement.



WARNING:

- If the power cord or plug is damaged, replacement must be performed by qualified electrical personnel.
- Do not connect or disconnect the power cord or attempt to operate buttons with wet hands. This could result in electrical shock.
- Because of potential safety hazards under a certain condition, we strongly recommend against the use of an extension cord. However, if you still elect to use an extension cord, it is absolutely necessary that it is a UL listed, 3-wire grounding type appliance extension cord, having a 3-blade and a 3-slot receptacle that plugs into the appliance. The marked rating of the extension cord should be the following rating or equivalent.

Model	Rating of Extension Cord
Climate Pro 12	125 V, 15 A

3. Check the power supply outlet rating and fuse size to match with table below.

Model	Minimum Power Supply Rating	Recommended Fuse Size
Climate Pro 12	115 V, 1 Phase, 60 Hz, 15 A	15 A maximum



CAUTION: The power source should be a dedicated single outlet circuit with UL recognized short-circuit and ground fault protective breaker. Do not share the power supply outlet with any other instrument or equipment. The minimum power supply rating and the recommended fuse size are listed above.

Note:

- Make sure the power supply outlet is free of dirt, dust, oil, water, or any other foreign matter.
- The Climate Pro 12 is equipped with UL recognized LCDI cord and NEMA plug configuration (5-15). The appropriate outlet must be used for this plug type.

INSTALLATION (cont.)

LCDI Power Cord Instruction

⚠ WARNING: This LCDI power cord is a non-serviceable device. Attempting to open the device may expose the user to the hazards of electric shock, and could void warranties of this product. Manufacture’s reliability is limited to the replacement of the device.

- ⚠ CAUTION:**
- Read the attention printed on the device for proper use and handling of this device.
 - This device is used for monitoring leakage current.
 - Do not immerse in water.
 - This device must only be plugged into an appropriate wall outlet. Do not remove the ground prong.
 - In the event that this device trips, the cause of malfunctions should be corrected first before further use.
 - Using the device beyond the recommended voltage poses risk to users.
 - Conductors inside this cord are surrounded by shields, which monitor leakage current.
 - These shields are not grounded, and they are periodically examined for any damage.
Do not use this product in the event the shields become exposed.
 - Do not repeatedly push TEST and/or RESET buttons.

Test Procedure

Test this device once when the power supply is installed to assure proper operation.

1. Plug into the grounded power receptacle.
2. If POWER light is not on, press RESET button once. Light should turn on.
3. Press TEST button once, POWER light must turn off.
4. Press RESET button once again for use. POWER light should turn on.
5. If this test fails, do not use this device. Contact a qualified technician for details.

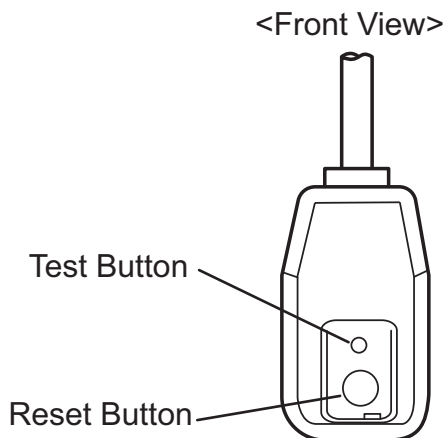

ILL00965-00

INSTALLATION (cont.)

External Thermostat Connection

The Climate Pro 12 comes with two types of external thermostat connections available to be connected with:

- a. An optional 24VAC transformer is required with a field supplied 24VAC thermostat. Follow the instruction steps provided with an optional 24VAC transformer for this connection.
- b. A MovinCool optional millivolt thermostat. Follow the steps below for the connection of a millivolt thermostat.



WARNING:

- **All electrical work must be performed by qualified personnel. Otherwise it may result in personal injury and/or damage to the unit.**
- **Disconnect power before installation. Beware that some residual voltage may remain in the unit immediately after the power is disconnected.**

External Millivolt Thermostat Connection (Optional Accessory)

1. Select the proper location where the millivolt thermostat can be conveniently accessed and install it at the selected location.



CAUTION: Do not install the millivolt thermostat where artificial heating condition may occur (i.e. hot stove, hot pipe, and fireplace or under direct sunlight).

2. Set the millivolt thermostat to cool or heat mode without power connection on the unit.
3. Prepare the millivolt thermostat wires.
Recommended wire size: 18 ~ 20 AWG
4. Turn the unit off and unplug the power cord.
5. Take out seven (7) screws and remove the service panel from rear of the unit.

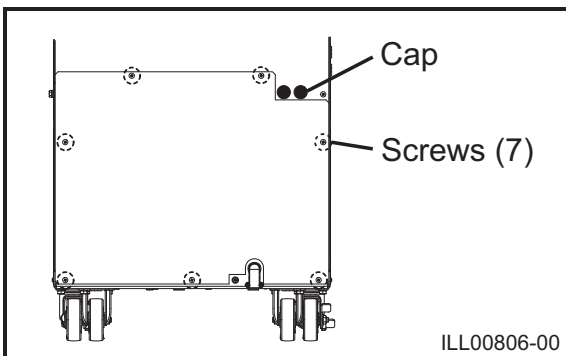

INSTALLATION (cont.)

External Thermostat Connection (cont.)

External Millivolt Thermostat Connection (Optional Accessory) (cont.)

6. Squeeze the inner latches and push out the black cap from inside the panel.

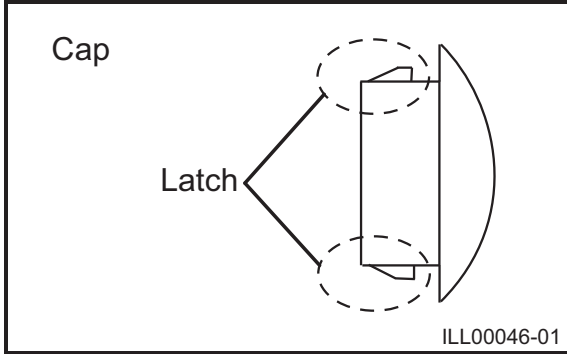

7. Insert the millivolt thermostat wires through the hole in the rear panel.

8. Connect the millivolt thermostat wires to the terminal block according to the connection table shown below.

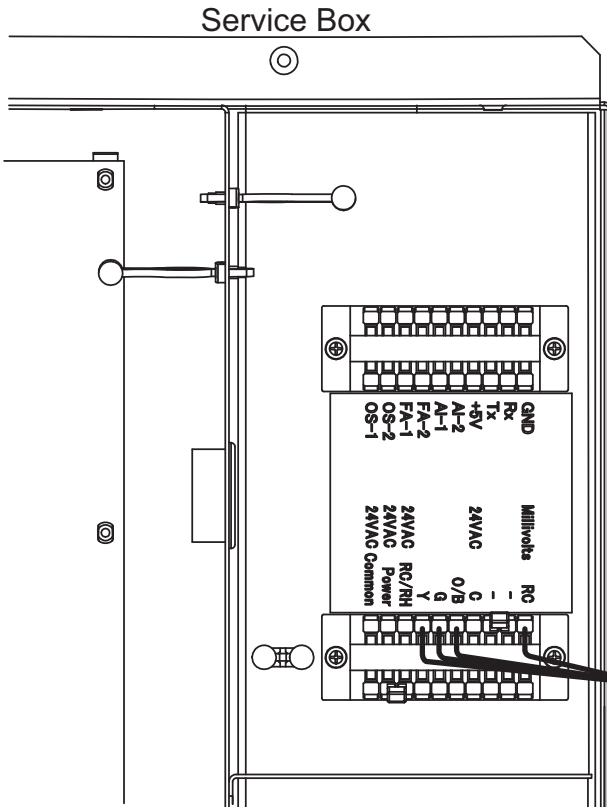

Connection Table

Millivolt Thermostat Wire No.	Unit Terminal Block Terminal No.
RC	Millivolts RC
O/B	O/B
G	G
Y	Y

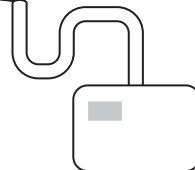

Millivolt Thermostat

ILL00776-00

9. Reinstall the service panel to the unit.

10. Refer to page 31 for activating an external thermostat on the unit's control panel.

INSTALLATION (cont.)

External Thermostat Connection (cont.)

External 24VAC Thermostat Connection (Field Supplied)

The Climate Pro 12 can also be connected with the external 24VAC thermostat where the 24VAC is readily available, simply follow the steps and connection table below.

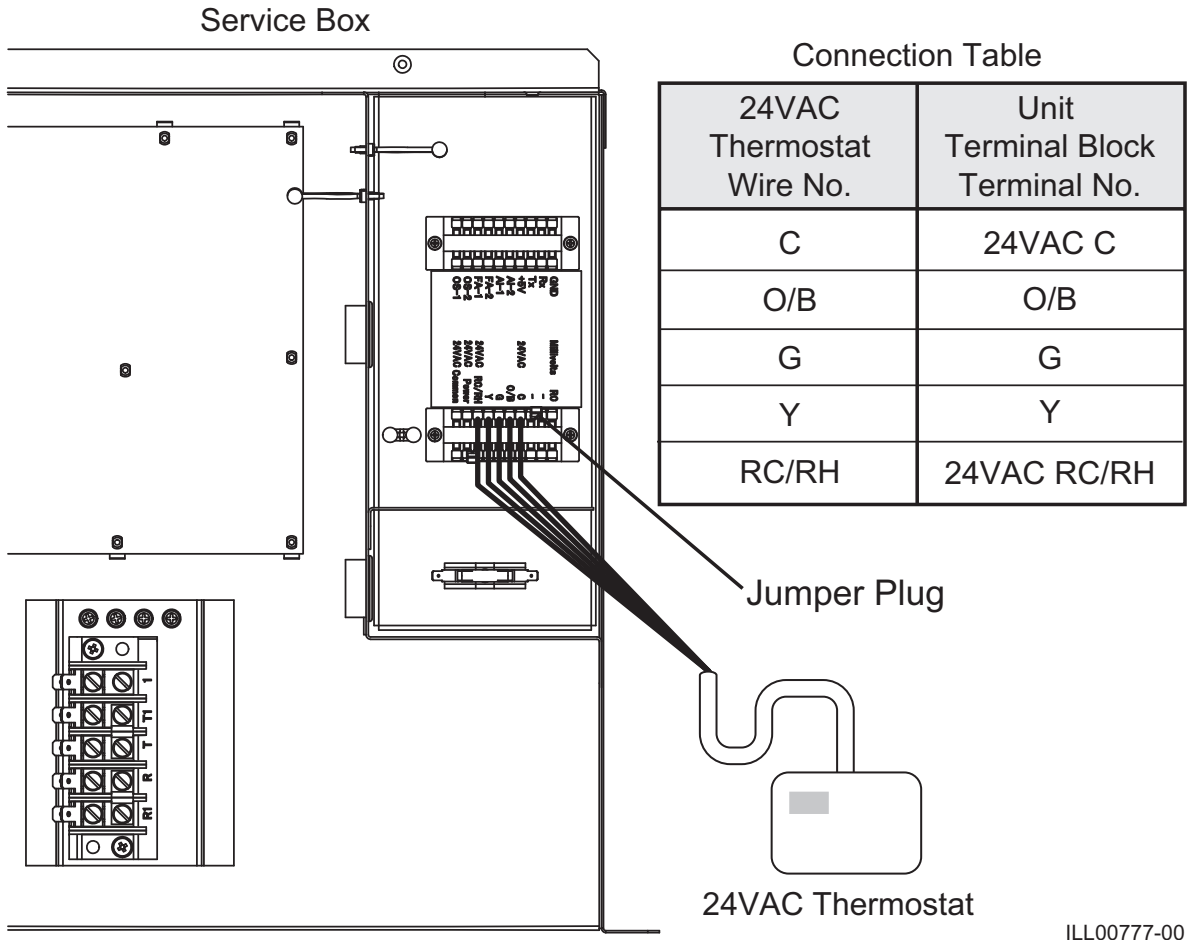

ILL00777-00

1. Refer to the previous section to remove the service panel and insert the thermostat wires through the hole in the rear panel.
2. Connect the 24VAC thermostat wires to the terminal block according to the connection table shown above.
3. Remove the jumper plug from the terminal block.
Note: Keep this jumper plug in a safe place to reuse when the 24VAC thermostat is removed from the unit.
4. Reinstall the service panel to the unit.
5. Refer to page 31 for activating an external thermostat on the unit's control panel.

INSTALLATION (cont.)

External Warning Device Connection

The controller of this unit is equipped with a warning signal output relay which can be used to monitor failure condition of the unit and is compatible with various external warning devices such as alarm speaker, light indicators, etc.

Relay type: Form C, normal open dry contact

Relay output contactor rating: 2 A at 30 V (DC/AC) or less (resistive load)



WARNING:

- **All electrical work must be performed by qualified personnel. Otherwise it may result in personal injury and/or damage to the unit.**
- **Disconnect power before installation. Beware that some residual voltage may remain in the unit immediately after the power is disconnected.**

1. Turn the unit off and unplug the power cord.
2. Take out seven (7) screws and remove the service panel from rear of the unit.

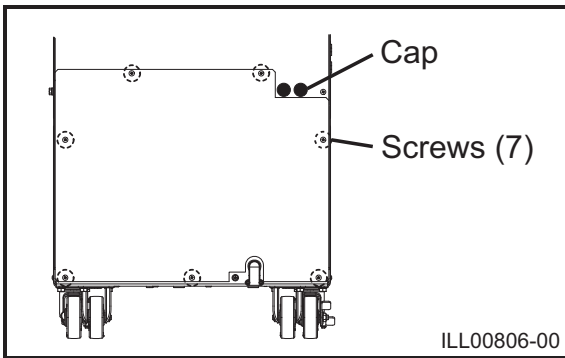

3. Squeeze the inner latches and push out the black cap from inside the panel.

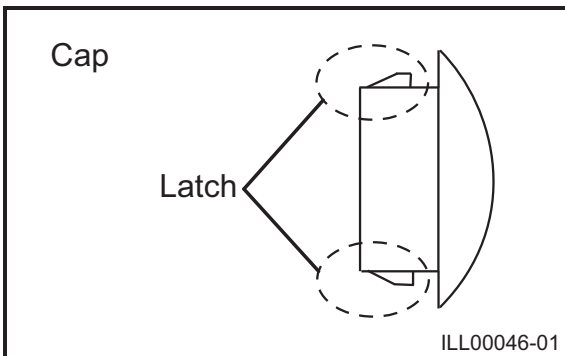

4. Insert the warning signal wires through the hole in the rear panel.
Recommended wire size: 16 AWG ~ 22 AWG

INSTALLATION (cont.)

External Warning Device Connection (cont.)

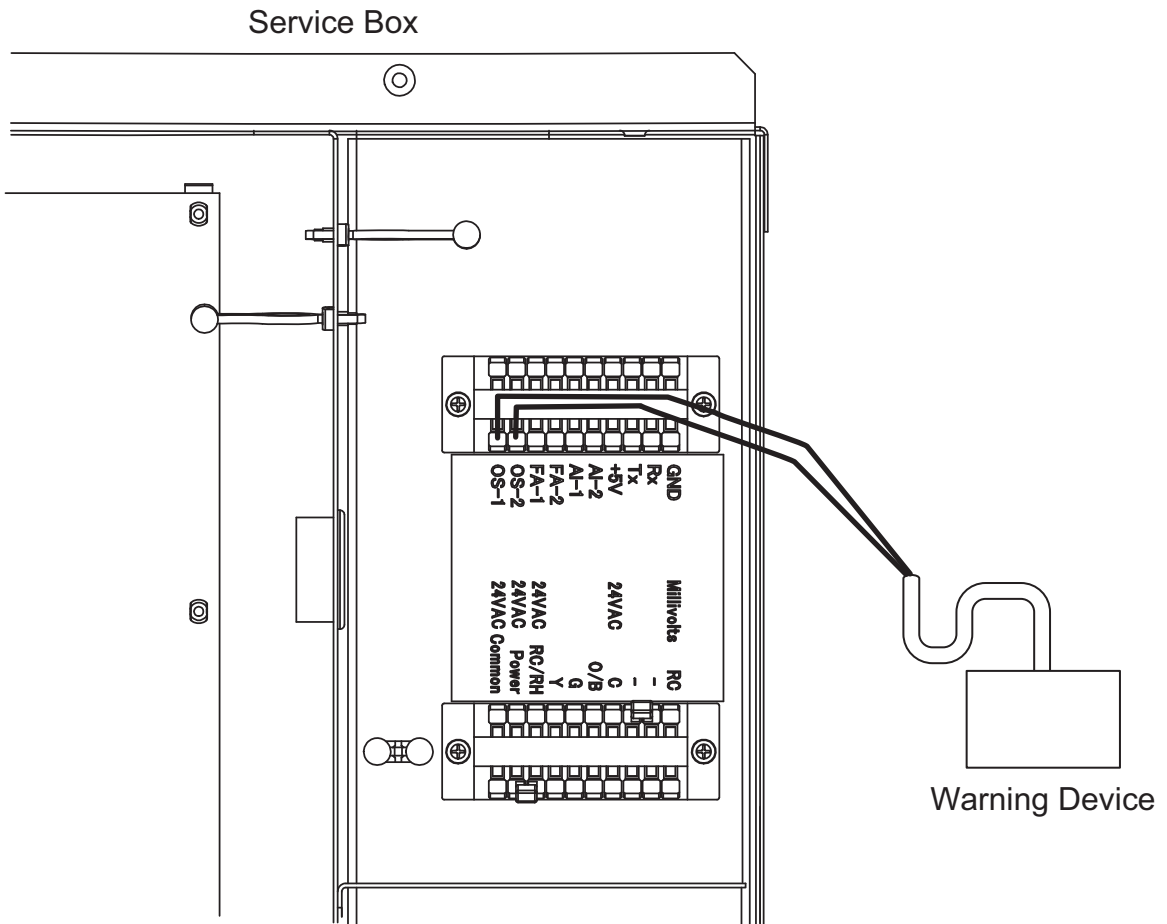

ILL00774-00

5. Connect the warning signal wires to the terminals OS-1 and OS-2 as shown in the above figure.
6. Reinstall the service panel to the unit.

INSTALLATION (cont.)

External Alarm Device Connection

The controller of this unit is equipped with two sets of input signal terminals on the terminal block which can connect the external alarm devices such as a fire alarm device. The input signal terminals should only be connected to a close or an open dry contact. When receiving the signals from the external alarm devices, the unit turns off and does not turn back on until it has been RESET.



WARNING:

- **All electrical work must be performed by qualified personnel. Otherwise it may result in personal injury and/or damage to the unit.**
- **Disconnect power before installation. Beware that some residual voltage may remain in the unit immediately after the power is disconnected.**

1. Turn the unit off and unplug the power cord.
2. Remove seven (7) screws and remove the service panel from rear of the unit.

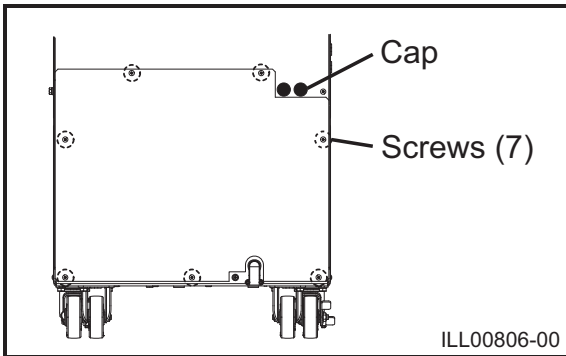

3. Squeeze the inner latches and push out the black cap from inside the panel.

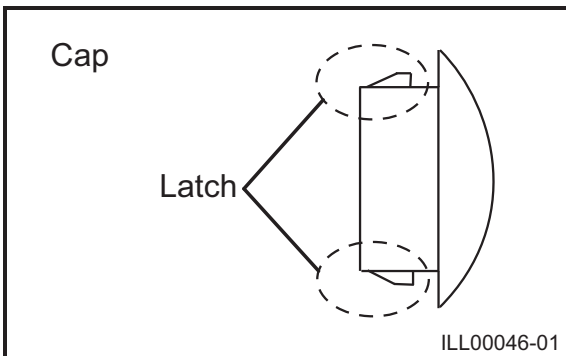

4. Insert the alarm signal wires through the hole in the rear panel.
Recommended wire size: 16 AWG ~ 22 AWG

INSTALLATION (cont.)

External Alarm Device Connection (cont.)

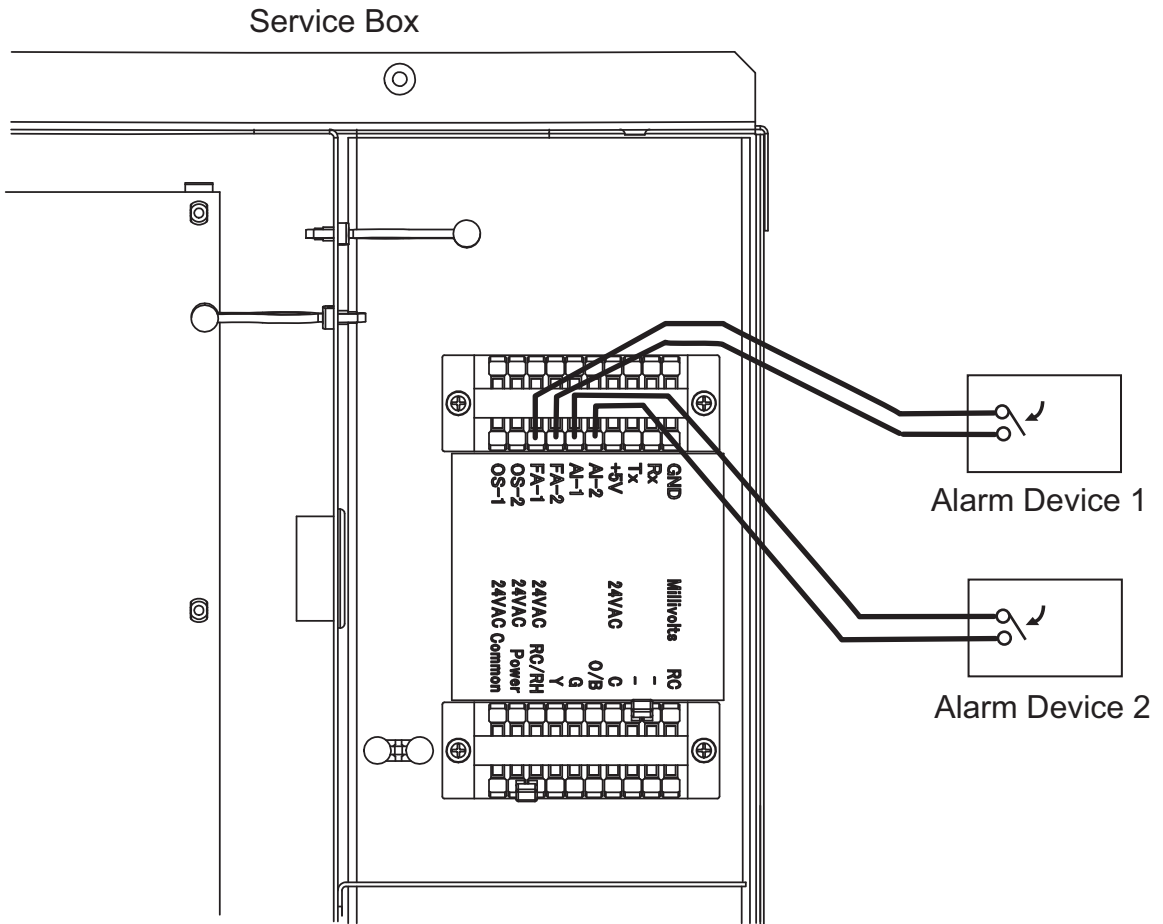

ILL00775-00

5. Connect the alarm signal wires to terminal AI-1 and AI-2 and/or FA-1 and FA-2 as shown in the above figure.
6. Reinstall the service panel to the unit.

FEATURES

1. Digital electronic control panel, which allows the user to easily control the unit's operation.
2. Three fan speeds (HI, MID, LO) in all modes (COOL, HEAT, FAN ONLY).
3. Large digital LCD display with two backlight colors and multiple lines of displayed characters that indicate:
 - Clock with day and time
 - Room temperature and set point temperature (°F or °C)
 - Cool, Heat, and Fan Only mode status
 - Fan speed and fan mode status
 - Confirmation screen to confirm selection status
 - Notification screen when an external thermostat is connected
 - Program set up and schedule to run and stop
 - Self-diagnostic codes with explanation
4. The set point temperature can be adjusted to maximum or minimum value depending on selected COOL or HEAT mode.
5. Automatic restart feature when the power is lost and regained. The unit returns to the same operation mode as it was prior to the loss of power. Any preset program is retained in the memory in the event power loss occurs.
6. Up to ten program slots are available to the user to program a specific time and day at which the unit automatically begins to operate and turn off.
7. Drain tank and optional condensate pump warning display with instruction.
8. Automatic shut off, warning signal output and alarm for temperature sensor failure, loss of cooling, and conditions of self-diagnostic codes.
9. External millivolt or 24VAC thermostat connection.
10. External alarm and warning device connection with automatic shut off.

OPERATION

Operation Modes

The Climate Pro 12 operates in three modes, COOL, HEAT, and FAN ONLY. The unit is in standby mode if it is not operating in these modes.

- **Standby Mode**

When the unit is connected to power, the LED illuminates in orange color, and the LCD displays date, time and the previous mode setting condition with blue backlight that stays on for 60 seconds, then turns off. The backlight turns on again if any button is pressed.

- **Cool Mode**

When the unit is in COOL mode operation, the compressor operates and cool air is circulated. Once the room temperature reaches the set point temperature, the unit operates in FAN ONLY mode. When switched from HEAT to COOL mode operation, the unit initially operates in FAN ONLY mode. Set point temperature range: 65 °F ~ 90 °F (18 °C ~ 32 °C)

- **Heat Mode**

When the unit is in HEAT mode operation, the compressor operates and hot air is circulated. Once the room temperature reaches the set point temperature, the unit stops. When switched from COOL to HEAT mode operation, the unit stops until the compressor operates. Set point temperature range: 55 °F ~ 80 °F (13 °C ~ 27 °C)

Note:

- *When FAN mode is set to AUTO, the fan operates within 1 minute after the compressor operates.*
- *When the ambient temperature falls outside the operating condition range, the unit automatically stops and displays "OUTSIDE OPERATING RANGE" on the control panel.*
- *When the ambient temperature is low, the unit automatically stops and starts defrosting operation for maximum 15 minutes ("DEFROST" is displayed on the control panel). The unit returns to heating operation after defrosting operation is completed.*
- **Temperature Control**

The room temperature thermistor monitors the inlet air temperature versus set point temperature and automatically switches ON and OFF during cooling or heating operation.
- **Fan Mode Control**

The fan mode control determines whether the fan continues to operate or stop when the compressor stops during COOL or HEAT mode. The unit has been preset at the factory for continuous fan operation in COOL and for fan AUTO operation in HEAT mode. Fan mode can be changed on the control panel under Menu.
- **Temperature Scale Display**

The unit has been preset at the factory to display the temperature in °F. The temperature scale can be changed from °F to °C on the control panel under Menu.

OPERATION (cont.)

Control Panel

Before operating the unit, it is important to familiarize yourself with the basic controls located on the control panel.

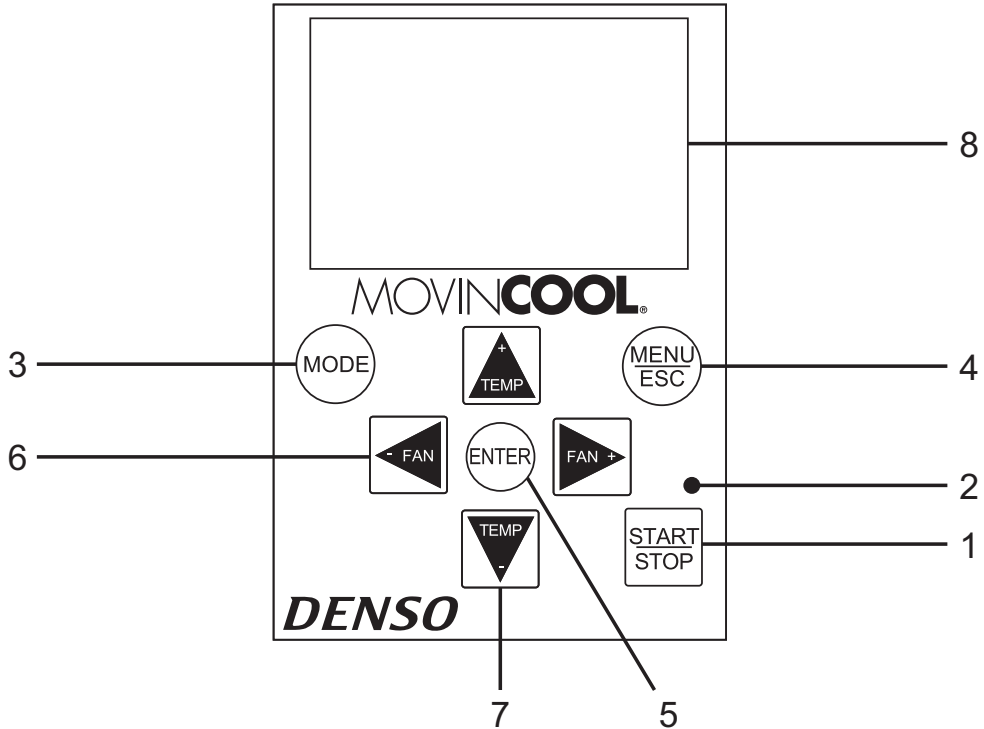

ILL00778-00

- | | |
|-------------------------|--|
| 1. START/STOP Button | Start or stop the unit operation. |
| 2. LED | Illuminate in Orange color for Self-Diagnostic and Standby mode, in Green color for normal operation. |
| 3. MODE Button | Select operation mode (Fan Only, Cool, and Heat). |
| 4. MENU/ESC Button | Display the menu selection screen or to escape from the menu selection screen. |
| 5. ENTER Button | Select item in Menu mode. |
| 6. FAN+, -FAN Buttons | Change fan speeds Hi, MID, LO. |
| 7. TEMP+, -TEMP Buttons | Change set point temperature. |
| 8. LCD | Display operation mode, status, notification, confirmation, and self-diagnostic codes with two backlight colors. |

OPERATION (cont.)

LCD Indicators

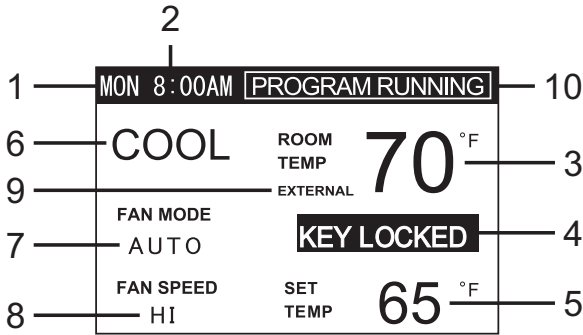

ILL00779-00

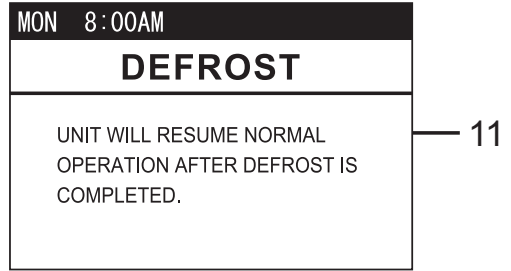

ILL00780-00

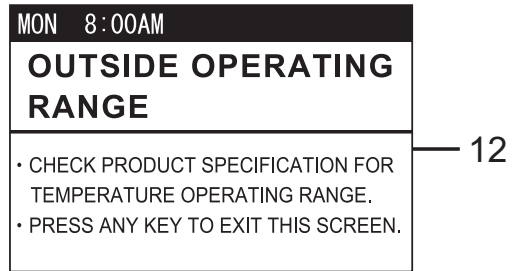

ILL00781-00

- | | |
|-----------------------------|---|
| 1. Day of the week | Indicate day of the week. |
| 2. Time of the day | Indicate time of the day. |
| 3. Room Temp | Indicate room temperature. |
| 4. Key Locked | Indicate keypad is locked. |
| 5. Set Temp | Indicate set point temperature. |
| 6. Fan Only/Cool/Heat | Indicate operating mode. |
| 7. Fan Mode | Indicate AUTO or ON. |
| 8. Fan Speed | Indicate HI, MID or LO. |
| 9. External | Indicate external millivolt or 24VAC thermostat is connected. |
| 10. Program Running | Indicate Program is running |
| 11. Defrost | Indicate defrost operation during heating. |
| 12. Outside Operating Range | Indicate the unit is used outside of the operating condition range. |

OPERATION (cont.)

Set Clock

Prior to operating the Climate Pro 12, set the clock of the controller to the correct time as shown in the following steps.

1. Press MENU button to go to MENU.
2. Use TEMP+ or -TEMP button to select SET CLOCK. Press ENTER button to start setting day of the week, hour, and minute.

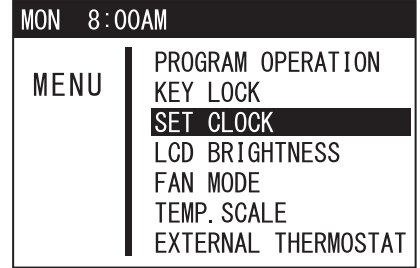

ILL00782-00

3. Use TEMP+ or -TEMP button to select day of the week, then press ENTER button to confirm. Follow the same procedure to set hour and minute.

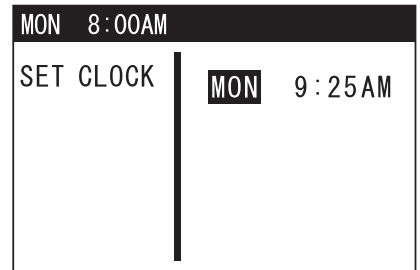

ILL00783-00

4. Once the minute has been selected, press ENTER button to complete, LCD automatically exits from SET CLOCK to the previous mode.

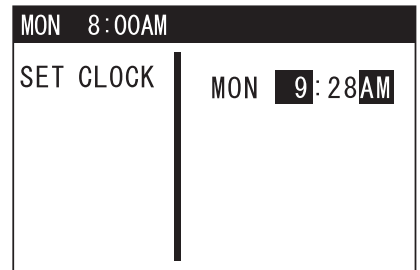

ILL00784-00

Note:

- If no button is pressed for 1 minute, LCD automatically displays the previous mode.
- Please check clock periodically to confirm clock accuracy.

OPERATION (cont.)

Cool Mode Operation

1. If the unit is in standby mode, simply press MODE button until "COOL" appears, then press START/STOP button. LCD displays a confirmation screen. Press START/STOP button once again to start COOL mode operation. LED color changes from orange to green.

Note: If no button is pressed for 1 minute, LCD automatically displays the previous mode.

2. If the unit is already in operation, press MODE button once. The operation status screen displays the current operation mode. Press TEMP+ or -TEMP button to go to COOL, then press ENTER button to select.

3. LCD displays a confirmation screen as shown on the right.

4. Use TEMP+ or -TEMP button to change set point temperature. LCD displays "MIN" or "MAX" when set point value is at minimum or maximum.
5. Use FAN+ or -FAN button to change fan speed (HI, MID, LO).

6. To stop COOL mode operation, press START/STOP button. LCD displays a confirmation screen. Press START/STOP button again. LED color changes from green to orange.

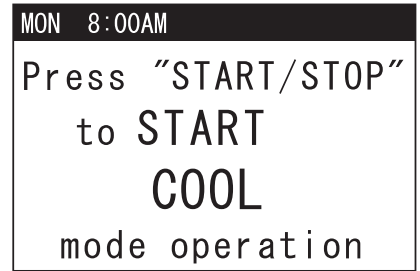

ILL00785-00

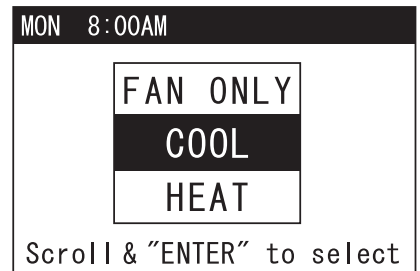

ILL00786-00

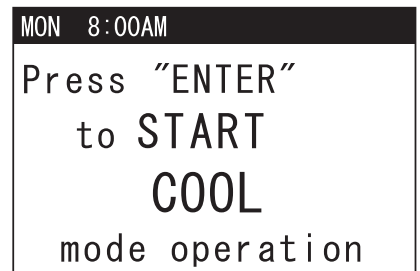

ILL00787-00

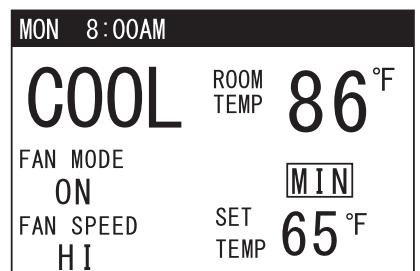

ILL00788-00

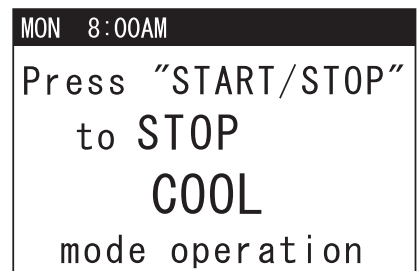

ILL00789-00

OPERATION (cont.)

Heat Mode Operation

1. If the unit is in standby mode, simply press MODE button until "HEAT" appears, then press START/STOP button. LCD displays a confirmation screen. Press START/STOP button once again to start HEAT mode operation. LED color changes from orange to green.

Note: If no button is pressed for 1 minute, LCD automatically displays the previous mode.

2. If the unit is already in operation, press MODE button once. The operation status screen displays the current operation mode. Press TEMP+ or -TEMP button to go to HEAT, then press ENTER button to select.

3. LCD displays a confirmation screen as shown on the right.

4. Use TEMP+ or -TEMP button to change set point temperature. LCD displays "MIN" or "MAX" when set point value is at minimum or maximum.

5. Use FAN+ or -FAN button to change fan speed (HI, MID, LO).

Note: When the ambient temperature is high, fan speed is automatically changed from LO to MID during HEAT mode operation.

6. To stop HEAT mode operation, press START/STOP button. LCD displays a confirmation screen. Press START/STOP button again. LED color changes from green to orange.

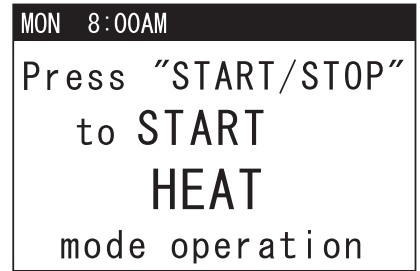

ILL00790-00

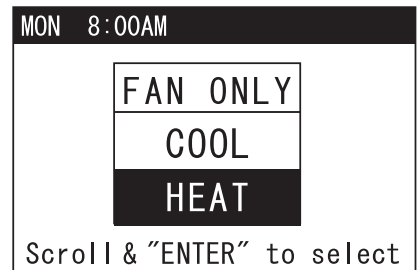

ILL00791-00

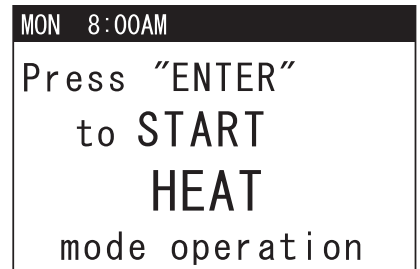

ILL00792-00

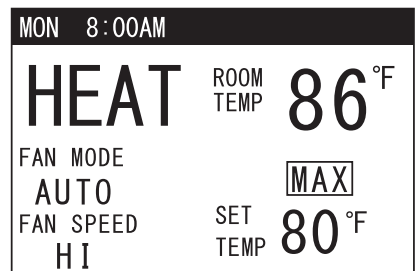

ILL00793-00

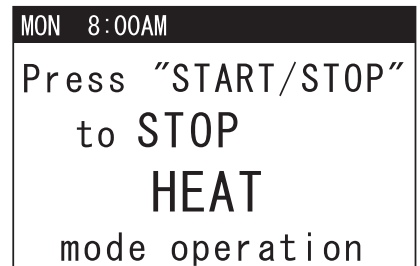

ILL00794-00

OPERATION (cont.)

Fan Only Mode Operation

1. If the unit is in standby mode, simply press MODE button until "FAN ONLY" appears, then press START/STOP button. LCD displays a confirmation screen. Press START/STOP button once again to start FAN ONLY mode operation. LED color changes from orange to green.

Note: If no button is pressed for 1 minute, LCD automatically displays the previous mode.

2. If the unit is in operation, simply press MODE button once. The operation status screen displays the current operation mode. Press TEMP+ or -TEMP button to go to FAN ONLY, then press ENTER button to select.

3. LCD displays a confirmation screen as shown on the right.

4. Use FAN+ or -FAN button to change fan speed (HI, MID, LO).

5. To stop FAN ONLY mode operation, press START/STOP button. LCD displays a confirmation screen. Press START/STOP button again. LED color changes from green to orange.

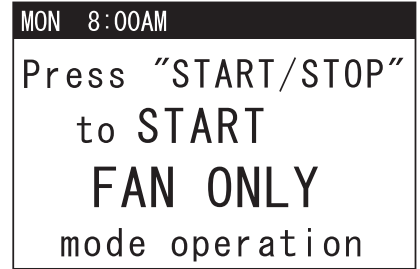

ILL00795-00

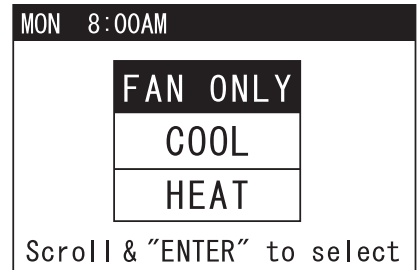

ILL00796-00

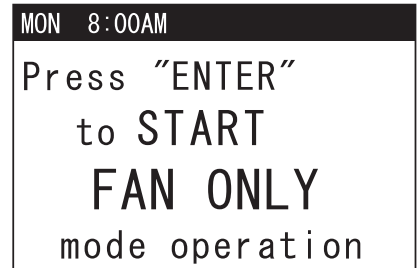

ILL00797-00



ILL00798-00

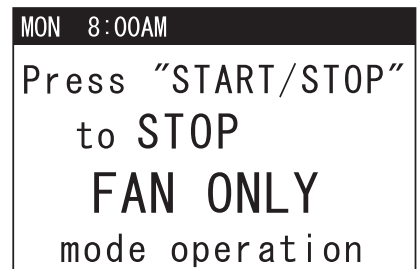

ILL00799-00

OPERATION (cont.)

Menu Features

The Climate Pro 12 has an on-screen Menu feature to easily change the setting by using buttons on the control panel. Features in Menu are limited when accessed during operation due to safety reason. All features in Menu are accessible in standby mode.

1. Press MENU/ESC button during standby mode or operation mode.
2. Use TEMP+ or -TEMP button to select the feature and press ENTER button to confirm.

Note:

- Press MENU/ESC button again to return to the previous screen or exit Menu.
- If no button is pressed for 1 minute, LCD displays the previous mode.

Menu features during standby mode

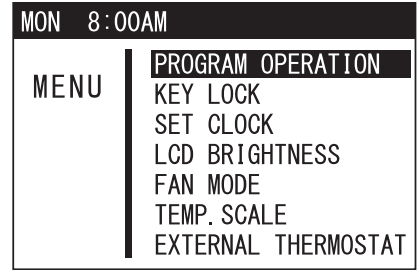

ILL00800-00

Menu features during operation mode

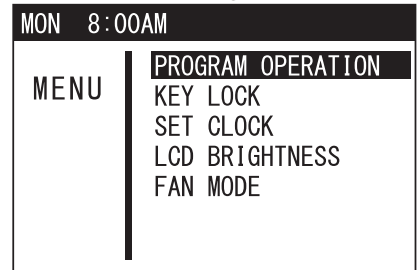

ILL00801-00

Key Lock and Unlock

Key lock is a feature under Menu and disables all buttons on the control panel except MENU/ESC button.

1. Press MENU/ESC button to go to MENU. Use TEMP+ or -TEMP button to select KEY LOCK. Select YES and press ENTER button to lock the buttons. LCD displays "KEY LOCKED".

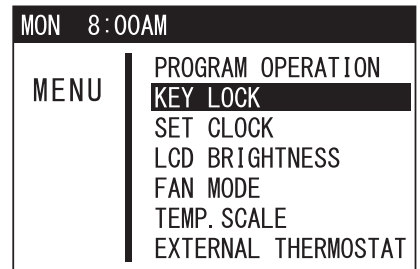

ILL00802-00

2. To unlock the buttons, press and hold MENU/ESC button for 5 seconds.

Note:

- Press MENU/ESC button again to return to the previous screen or exit Menu.
- If no button is pressed for 1 minute, LCD displays the previous mode.
- All buttons are automatically unlocked when a self-diagnostic code is displayed.

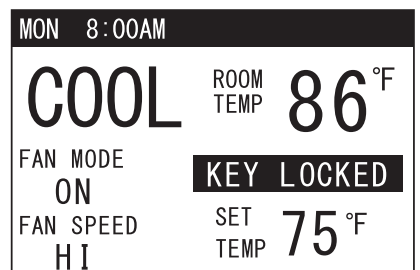

ILL00803-00

OPERATION (cont.)

Fan Mode Control

The fan mode control determines whether the fan continues to operate or stop when the room temperature reached the set point temperature. The unit has been preset at the factory for continuous fan operation.

1. Press MENU/ESC button to go to MENU.
Note: If no button is pressed for 1 minute, LCD displays the previous mode.

2. Use TEMP+ or -TEMP button to select FAN MODE and press ENTER button to confirm.

3. Use TEMP+ or -TEMP to select fan mode for heating or cooling, then use FAN+ or -FAN button to select AUTO or ON and press ENTER button to confirm.

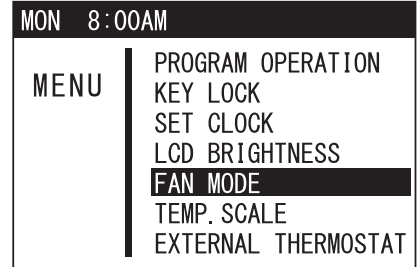

ILL00807-00

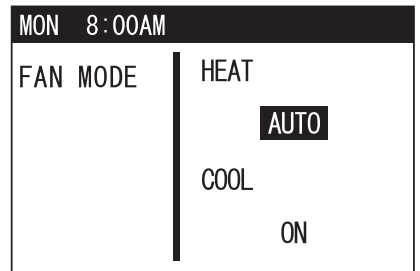

ILL00808-00

LCD Brightness Adjustment

1. Press MENU/ESC button to go to MENU.
Note: If no button is pressed for 1 minute, LCD displays the previous mode.

2. Use TEMP+ or -TEMP button to select LCD BRIGHTNESS and press ENTER button to confirm.

3. Use FAN+ or -FAN button to adjust the brightness level, then press ENTER button to confirm. The LCD automatically displays the previous mode.

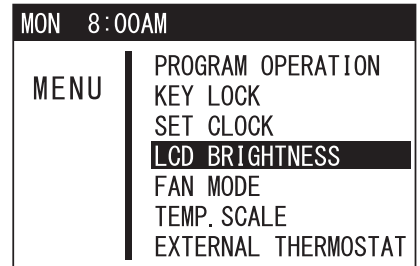

ILL00809-00

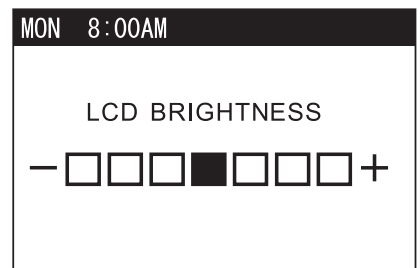

ILL00810-00

OPERATION (cont.)

Changing Temperature Scale

1. Press MENU/ESC button to go to MENU.
Note: If no button is pressed for 1 minute, LCD displays the previous mode.
2. Use TEMP+ or -TEMP button to select TEMP. SCALE and press ENTER button to confirm.
3. Use TEMP+ or -TEMP button to select °F or °C and press ENTER button to confirm.

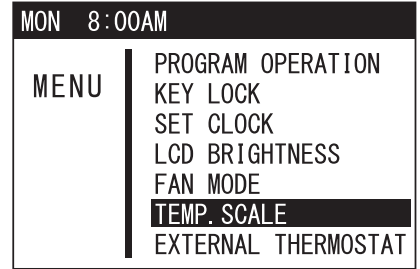

ILL00811-00

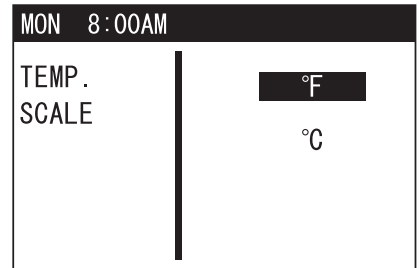

ILL00812-00

Activating External Thermostat

1. Press MENU/ESC button to go to MENU.
Note: If no button is pressed for 1 minute, LCD displays the previous mode.
2. Use TEMP+ or -TEMP to select EXTERNAL THERMOSTAT and press ENTER button to confirm. LCD displays a notification screen.
3. Use TEMP+ or -TEMP button to select YES and press ENTER button to confirm. LCD displays "EXTERNAL THERMOSTAT ACTIVATED" and "KEY LOCKED" with the room temperature. LED color changes from orange to green.
4. To deactivate thermostat connection, press and hold MENU button for 5 seconds. Other buttons are unlocked and the unit enters standby mode. LED color changes from green to orange.

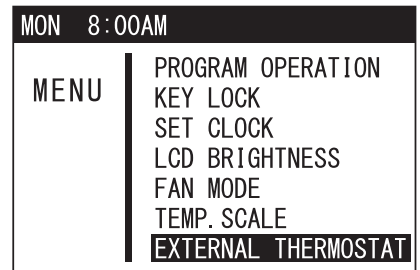

ILL00813-00

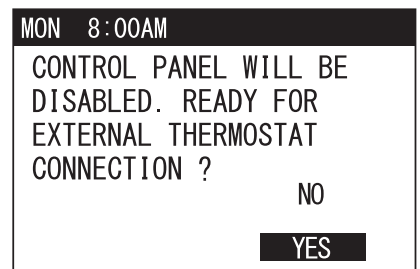

ILL00814-00

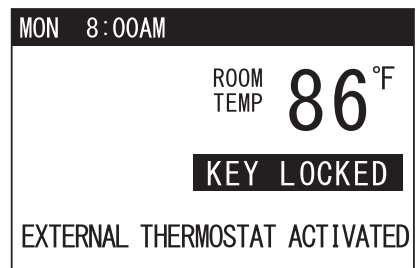

ILL00815-00

OPERATION (cont.)

Program Operation and Schedule

Setting Program

1. Press MENU/ESC button to go to MENU.
Note: If no button is pressed for 1 minute, LCD displays the previous mode.
2. Use TEMP+ or -TEMP button to select PROGRAM OPERATION and press ENTER button to confirm.

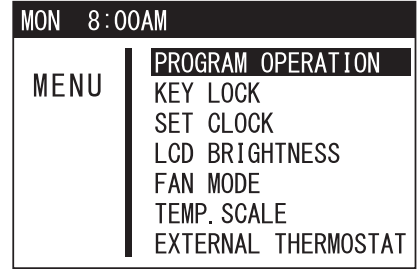

ILL00816-00

3. Select SET under program operation feature and press ENTER button to confirm.

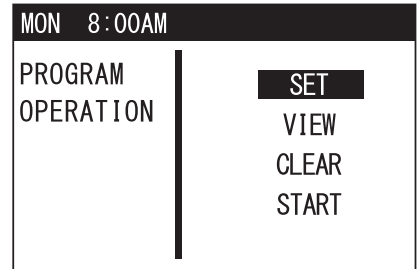

ILL00817-00

4. Press ENTER button again to start program setting. Use TEMP+ or -TEMP button to change each value (start time ~ fan speed) and press ENTER button to confirm. Repeat this step. There are 10 available program slots (P1 ~ P10). Program slots that have been set are indicated in a square box.

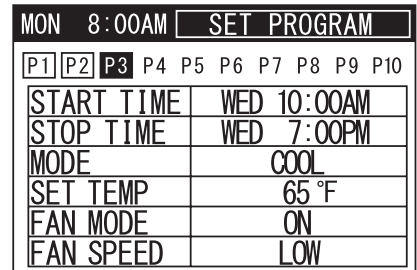

ILL00818-00

Note:

- Program counts period from the start time and day of P1 to the stop time and day of the last program. Program period can not be overlapped.
 - If MENU/ESC button is pressed during start time to fan speed setting, a program is not completed.
 - Use FAN+ or -FAN button to scroll through the preset program slots and access its content.
5. When setting is completed, press MENU/ESC button to exit from program setting.

Note: Follow the above steps to edit any preset program slot.

OPERATION (cont.)

Program Operation and Schedule (cont.)

Viewing Program

1. Press MENU/ESC button to go to MENU.
Note: If no button is pressed for 1 minute, LCD displays the previous mode.
2. Use TEMP+ or -TEMP button to select PROGRAM OPERATION and press ENTER button to confirm.
3. Select VIEW under program operation feature and press ENTER button to confirm.
4. Use FAN+ or -FAN button to scroll through the set program slots and view its content.

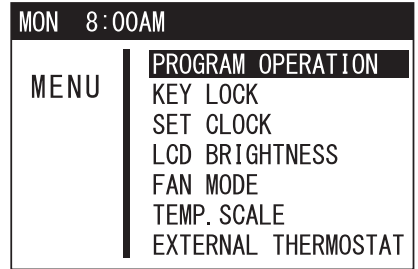

ILL00816-00

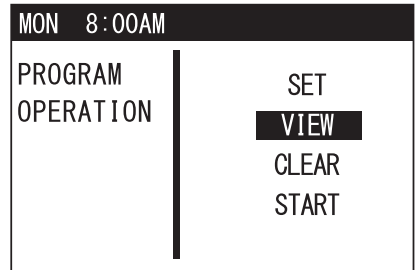

ILL00843-00

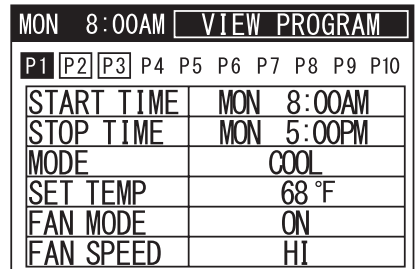

ILL00819-00

Clearing All Programs Slots

This feature clears the program in all the slots and each program slot content returns to the default value.

1. Select CLEAR under program operation feature and press ENTER button to confirm.
2. LCD displays a confirmation screen. Use TEMP+ or -TEMP button to select YES and press ENTER button to confirm.

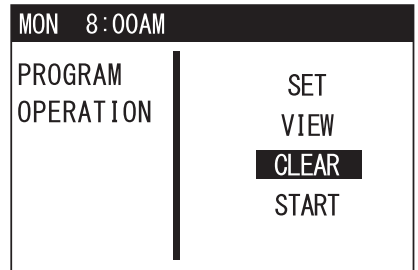

ILL00820-00

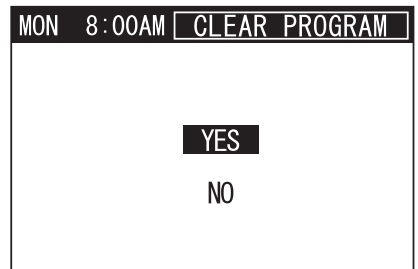

ILL00821-00

OPERATION (cont.)

Program Operation and Schedule (cont.)

Clearing Each Program Slot

This feature clears each set program slot and its content returns to the default value.

1. Press MENU/ESC button to go to MENU.
Note: If no button is pressed for 1 minute, LCD displays the previous mode.
2. Use TEMP+ or -TEMP button to select PROGRAM OPERATION and press ENTER button to confirm.
3. Select SET under program operation feature and press ENTER button to confirm.
4. Use FAN+ or -FAN button to select the set program slot.
5. Press and hold TEMP+ and -TEMP buttons to clear the program slot content.

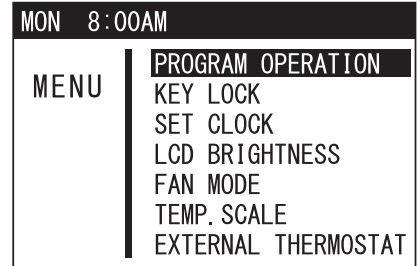

ILL00816-00

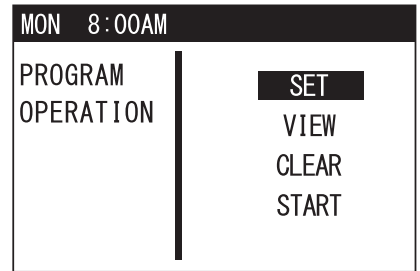

ILL00817-00

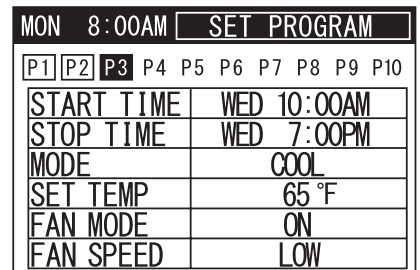

ILL00818-00

OPERATION (cont.)

Program Operation and Schedule (cont.)

Starting Program Operation

This feature starts unit operation according to the preset program slots.

1. Press MENU/ESC button to go to MENU.
Note: If no button is pressed for 1 minute, LCD displays the previous mode.

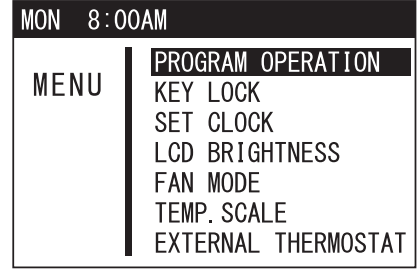

ILL00816-00

2. Use TEMP+ or -TEMP button to select PROGRAM OPERATION and press ENTER button to confirm.

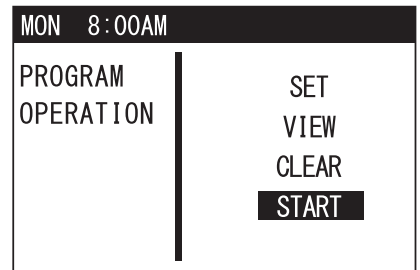

ILL00822-00

3. Select START under program operation feature and press ENTER button to confirm.

4. LCD displays a confirmation screen as shown on the right.

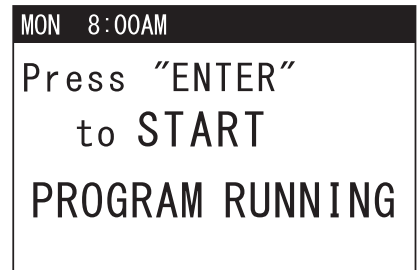

ILL00823-00

Note:

- When program starts running, LCD displays "PROGRAM RUNNING" and "KEY LOCKED" with room temperature. LED turns green.
- LCD backlight always stays on during cooling, heating, or fan only operation when program is running.
- LCD backlight turns off during standby mode when program is running. LED stays green.

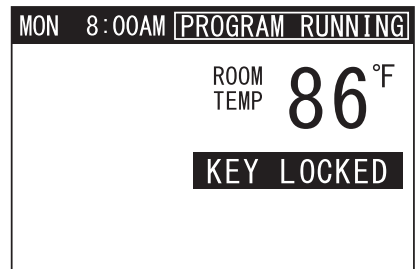

ILL00824-00

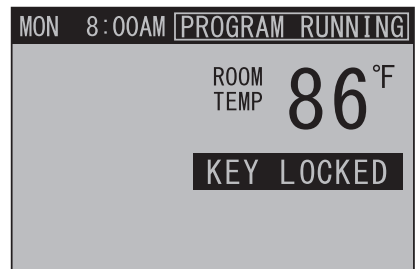

ILL00825-00

OPERATION (cont.)

Program Operation and Schedule (cont.)

Stopping Program Operation

1. Press and hold MENU/ESC button for 5 seconds to unlock other buttons.

After unlocked, if the unit was in standby mode, LCD only shows room temperature and “Press MENU to continue”.

Note: If no button is pressed for 1 minute, LCD screen displays the previous mode.

2. Press MENU/ESC button to go to MENU. Use TEMP+ or -TEMP button to select STOP and press ENTER button.

3. LCD displays a confirmation screen as shown on the right.

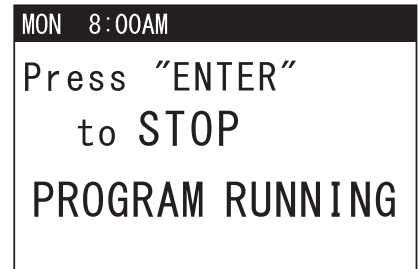
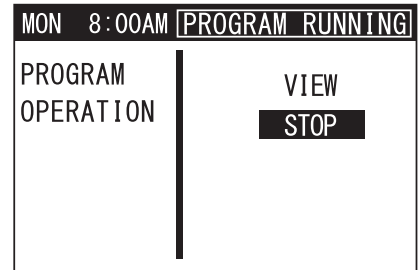
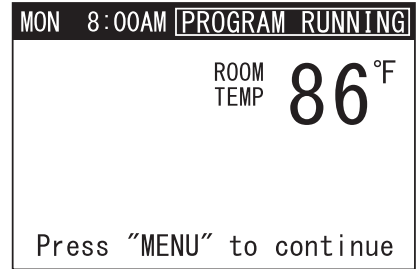

OPERATION (cont.)

Self-Diagnostic Codes

The Climate Pro 12 has an on-screen self-diagnostic feature that provides a quick and easy way to troubleshoot issues within the unit. The LCD screen displays self-diagnostic codes with backlight in orange color to easily distinguish from normal operation conditions.

Self-Diagnostic Codes - Table 1

Code	Condition	LCD Display and Description
AL1	Alarm device 1 is activated.	<p>MON 8:00AM</p> <p>DIAGNOSTIC CODE:AL1</p> <p>ALARM1 ACTIVATED</p> <p>1)CHECK FA-1,FA-2 CONNECTION. 2)IDENTIFY AND CORRECT CONDITION CAUSING THE ALARM. 3)RESET BY PRESS AND HOLD FAN+ AND FAN- FOR 5 SECONDS. 4)CONTACT THE DEALER OR A QUALIFIED TECHNICIAN.</p> <p>ILL00829-00</p>
AL2	Alarm device 2 is activated.	<p>MON 8:00AM</p> <p>DIAGNOSTIC CODE:AL2</p> <p>ALARM2 ACTIVATED</p> <p>1)CHECK AI-1,AI-2 CONNECTION. 2)IDENTIFY AND CORRECT CONDITION CAUSING THE ALARM. 3)RESET BY PRESS AND HOLD FAN+ AND FAN- FOR 5 SECONDS. 4)CONTACT THE DEALER OR A QUALIFIED TECHNICIAN.</p> <p>ILL00830-00</p>
FL	Drain tank is full.	<p>MON 8:00AM</p> <p>DIAGNOSTIC CODE:FL</p> <p>DRAIN TANK IS FULL</p> <p>1)DRAIN WATER FROM TANK. 2)PLACE TANK BACK IN THE UNIT. 3)PRESS START/STOP TO START.</p> <p>ILL00831-00</p>
HP	High pressure protection is activated.	<p>MON 8:00AM</p> <p>DIAGNOSTIC CODE:HP</p> <p>HIGH PRESSURE PROTECTION ACTIVATED</p> <p>1)CLEAN AIR FILTERS. 2)ENSURE 24" CLEARANCE IN FRONT OF THE UNIT AIR INLETS. 3)CHECK OPERATING TEMPERATURE AND HUMIDITY CONDITION. ▼</p> <p>ILL00832-00</p>

Note: Use TEMP+ or -TEMP button to scroll down the LCD screen with "▼" mark.

OPERATION (cont.)

Self-Diagnostic Codes (cont.)

Self-Diagnostic Codes - Table 2

Code	Condition	LCD Display and Description
AS	Optional condensate pump error	<p>MON 8:00AM</p> <p>DIAGNOSTIC CODE:AS</p> <p>CONDENSATE PUMP AND/OR CONNECTION ERROR</p> <p>1)CHECK DRAIN LINE FOR KINK, BLOCKAGE,AND IMPROPER ROUTING. 2)IDENTIFY AND CORRECT CONDITION. 3)RESET BY PRESS AND HOLD FAN+ AND FAN- FOR 5SECONDS. 4)CONTACT THE DEALER OR A QUALIFIED TECHNICIAN.</p> <p>ILL00833-00</p>
CF	Cooling or heating function failure	<p>MON 8:00AM</p> <p>DIAGNOSTIC CODE:CF</p> <p>REFRIGERANT LEAK AND/OR REFRIGERANT BLOCKAGE AND/OR OVERLOAD RELAY OF COMPRESSOR FAILURE</p> <p>Contact the dealer or a qualified technician.</p> <p>ILL00834-00</p>
E1	RTS thermistor failure	<p>MON 8:00AM</p> <p>DIAGNOSTIC CODE:E1</p> <p>RTS THERMISTOR FAILURE</p> <p>CONTACT THE DEALER OR A QUALIFIED TECHNICIAN.</p> <p>ILL00835-00</p>
E2	ODS thermistor failure	<p>MON 8:00AM</p> <p>DIAGNOSTIC CODE:E2</p> <p>ODS THERMISTOR FAILURE</p> <p>CONTACT THE DEALER OR A QUALIFIED TECHNICIAN.</p> <p>ILL00836-00</p>

OPERATION (cont.)

Self-Diagnostic Codes (cont.)

Self-Diagnostic Codes - Table 3

Code	Condition	LCD Display and Description
E3	CTS1 thermistor failure	<div style="border: 1px solid black; padding: 5px;"> <p>MON 8:00AM</p> <p>DIAGNOSTIC CODE: E3</p> <p>CTS1 THERMISTOR FAILURE</p> <hr/> <p>CONTACT THE DEALER OR A QUALIFIED TECHNICIAN.</p> </div> <p style="text-align: right; font-size: small;">ILL00837-00</p>
E4	CTS2 thermistor failure	<div style="border: 1px solid black; padding: 5px;"> <p>MON 8:00AM</p> <p>DIAGNOSTIC CODE: E4</p> <p>CTS2 THERMISTOR FAILURE</p> <hr/> <p>CONTACT THE DEALER OR A QUALIFIED TECHNICIAN.</p> </div> <p style="text-align: right; font-size: small;">ILL00838-00</p>
E5	CTS3 thermistor failure	<div style="border: 1px solid black; padding: 5px;"> <p>MON 8:00AM</p> <p>DIAGNOSTIC CODE: E5</p> <p>CTS3 THERMISTOR FAILURE</p> <hr/> <p>CONTACT THE DEALER OR A QUALIFIED TECHNICIAN.</p> </div> <p style="text-align: right; font-size: small;">ILL00839-00</p>

OPERATION (cont.)

Emptying the Drain Tank

During COOL or HEAT mode, the condensate water accumulates in the drain tank. When the drain tank becomes full, the LCD displays self-diagnostic code “FL” with backlight in orange color and the unit turns off automatically.

Note: To empty the drain tank while the unit is in operation, press START/STOP button to turn the unit off. If a program is running, stop program operation first (see “Program Operation and Schedule” section).

1. Open the drain tank door.
2. Pull the drain tank from the unit.
3. Remove the cap and empty the drain tank.
4. Replace the cap and return the drain tank to the unit.
5. Close the drain tank door.
6. Press START/STOP button to restart unit operation.

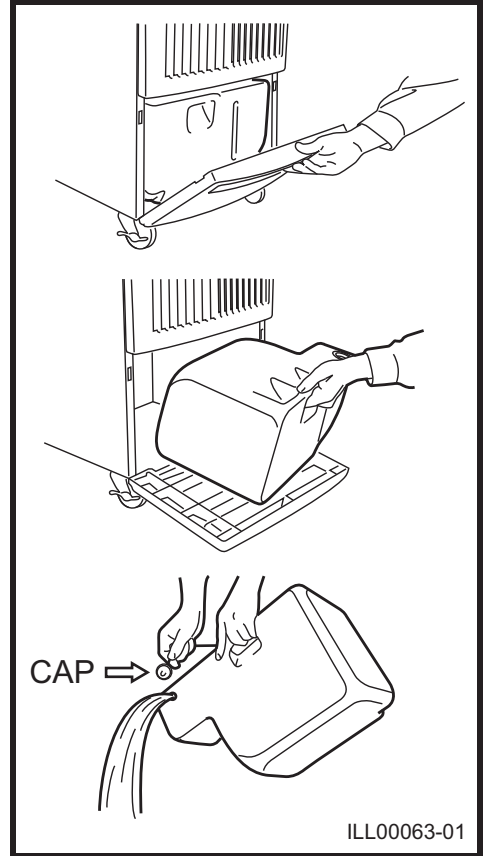

OPERATION (cont.)

Condensate Pump Kit (Optional Accessory)

The condensate pump kit is available to allow continuous unit operation and eliminate the need for emptying the drain tank.

When the water collects to level A in the pump reservoir, the condensate pump automatically discharges the water.

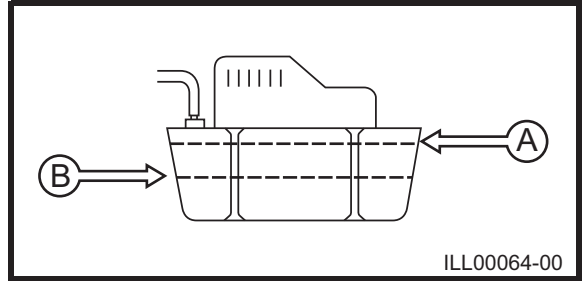

Note: The compressor does not operate while the condensate pump is discharging the water out from the reservoir.

When the water level drops below level B, the condensate pump stops, and the compressor restarts.

Note:

- *If for any reason the water level exceeds that of level A in the pump reservoir, an overflow drain switch stops the unit operation, and the LCD displays "AS".*
- *If the fan mode is set to AUTO, the entire unit (including fan operation) turns off either due to the overflow drain switch or while the condensate pump is discharging the water.*

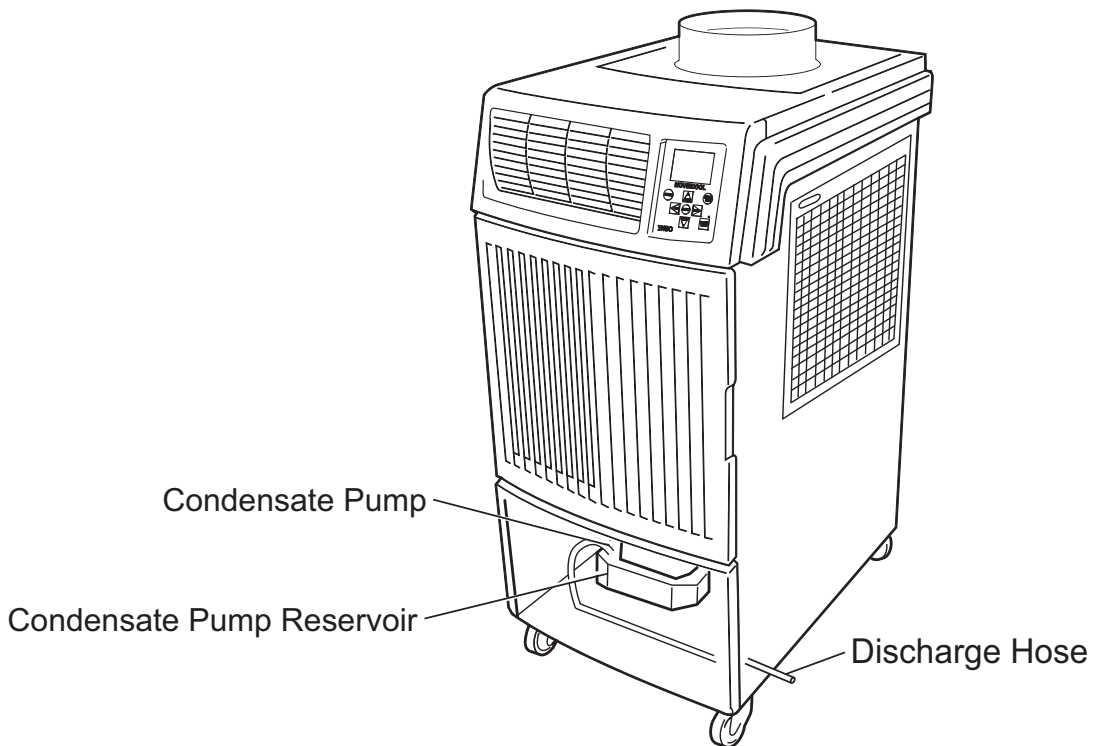

ILL00966-00

DAILY MAINTENANCE

Emptying the Drain Tank

See “Emptying the Drain Tank” section.

Air Filter Maintenance

Clean the air filters once a week if the unit is used in a dusty environment.

Note: The dirty air filters can reduce air output resulting in a decreased cooling or heating capacity.

Removing the Air Filters

1. Turn the unit off by pressing START/STOP button. If a program is running, stop program operation first (see “Program Operation and Schedule” section).
2. Open the side panel filter door and carefully remove the filter by pulling out the wire frame at two points shown in the figure.
3. Open the front panel filter door and carefully remove the filter from the wire frame by pulling its clips at two points shown in the figure.

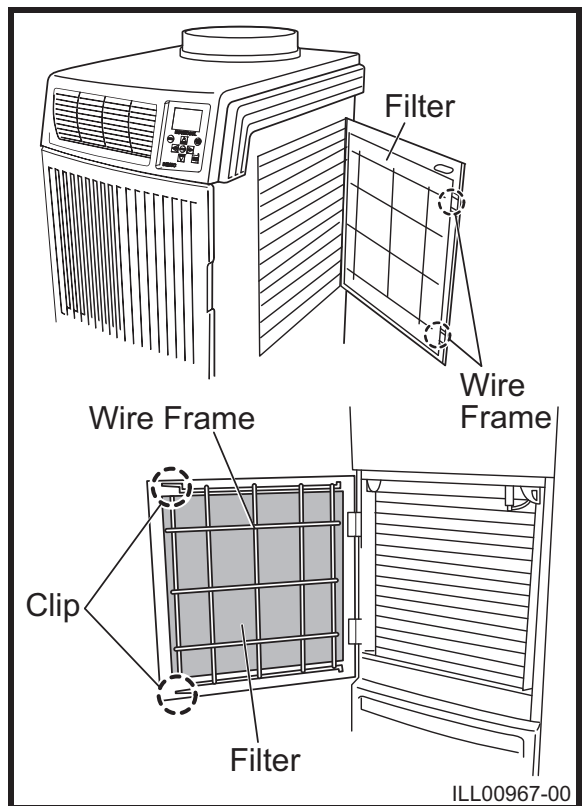

Cleaning the Air Filters

1. Remove dust from the filters with a vacuum cleaner, or rinse in cold or lukewarm water. If the filters are extremely dirty, wash with a neutral detergent.
2. After the filters are cleaned, rinse with clean running water, allow to dry, then reinstall.

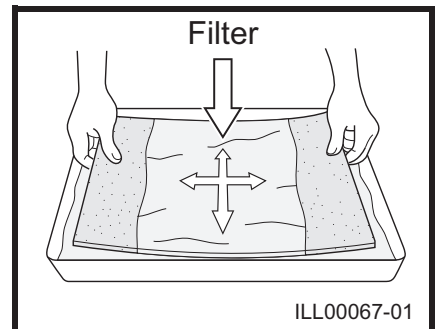

SEASONAL MAINTENANCE



WARNING:

- To prevent an accident due to electrical shock, perform inspection and maintenance only after unplugging the power cord.
- Do not use water to clean inside this unit. Exposure to water can destroy the insulation and electrical components, leading to electric shock. Interior cleaning must be performed by authorized personnel only. Consult your MovinCool dealer.

In-Season

In order for the unit to perform properly, conduct thorough inspection and maintenance on a regular basis.

1. Turn the unit off and unplug the power cord from the power supply outlet.
2. Check the power cord. If dirty, wipe off with a clean dry cloth. If damage or excess play is found, contact your MovinCool dealer for replacement.
3. Check the air filters and clean if dirty. If damage is found, replace it.
4. Check the drain tank and empty the water. If damage is found, replace it.
5. Check the exterior of the unit. If dirty, clean with a damp cloth or mild nonabrasive cleaner. If any part requires repair or replacement, contact your MovinCool dealer or a qualified technician.

Off-Season

1. Operate the unit in FAN ONLY mode for 8 hours.
Note: Operation is necessary to dry out the inside of the unit.
2. Turn the unit off and unplug the power cord from the power supply outlet.
3. Check the power cord. If dirty, wipe off with a clean dry cloth. If damage or excess play is found, contact your MovinCool dealer for replacement.
4. Check the air filters and clean if dirty. If damage is found, replace it.
5. Check the drain tank and empty the water. If damage is found, replace it.
6. Check the exterior of the unit. If dirty, clean with a damp cloth or mild nonabrasive cleaner. If any part requires repair or replacement, contact your MovinCool dealer or a qualified technician.
7. Store the unit for the next season in a clean and dry environment.

TROUBLESHOOTING

Check the following conditions before calling your MovinCool dealer or qualified technician.

Troubleshooting - Table 1

Condition		Check Area	Possible Cause	Remedy
Unit does not operate at all.	No display on LCD screen.	Voltage	Power failure	Check and fix power supply and connection.
				Check and turn the circuit breaker on.
		Ground fault protective breaker	Ground fault protective breaker is tripped.	Reset the ground fault protective breaker.
		LCDI power cord	Power cord is tripped.	Reset the power cord.
			Power cord is damaged.	Replace the power cord.
	Fuse on the relay board	Fuse is blown.	Check a fuse on the relay board. If a fuse is blown, check power supply and check for short, then replace a fuse on the relay board.	
	LCD displays self-diagnostic codes.	AL1	Alarm device 1 is activated.	<ol style="list-style-type: none"> 1. Check FA-1, FA-2 connection. 2. Identify and correct condition causing the alarm. 3. Press and hold FAN+ and -FAN buttons for 5 seconds to reset.
		AL2	Alarm device 2 is activated.	<ol style="list-style-type: none"> 1. Check AI-1, AI-2 connection. 2. Identify and correct condition causing the alarm. 3. Press and hold FAN+ and -FAN buttons for 5 seconds to reset.
		FL	Drain tank is full.	<ol style="list-style-type: none"> 1. Drain the water from the tank. 2. Place the tank back in the unit. 3. Press START/STOP button to start.

If conditions persist after the above remedies have been taken, turn the unit off, unplug the power cord from the power supply outlet, and contact your MovinCool dealer or a qualified technician.

TROUBLESHOOTING (cont.)

Troubleshooting - Table 2

Condition		Check Area	Possible Cause	Remedy
Unit does not operate at all.	LCD displays self-diagnostic codes.	HP	High pressure protection is activated.	<ol style="list-style-type: none"> 1. Clean the air filters. 2. Ensure 24 inch (610 mm) clearance in front of the unit air inlets. 3. Check operating temperature and humidity condition. 4. Ensure air flow is not blocked or restricted. 5. Press and hold FAN+ and -FAN buttons for 5 seconds to reset.
		AS	Optional condensate pump and/or connection error	<ol style="list-style-type: none"> 1. Check the drain line for kink, blockage and improper routing. 2. Identify and correct condition. 3. Press and hold FAN+ and -FAN buttons for 5 seconds to reset.
		CF	Refrigerant problem	Contact your dealer or a qualified technician.
		E1	RTS thermistor failure	Contact your dealer or a qualified technician.
		E2	ODS thermistor failure	
		E3	CTS1 thermistor failure	
		E4	CTS2 thermistor failure	
	E5	CTS3 thermistor failure		
	LCD displays notification.	OUTSIDE OPERATING RANGE	Unit is operating outside operating range.	Check product specification for temperature operating range. Press any key to exit.
		DEFROST	Unit is under defrost control.	Wait until defrost control is completed.

If conditions persist after the above remedies have been taken, turn the unit off, unplug the power cord from the power supply outlet, and contact your MovinCool dealer or a qualified technician.

TROUBLESHOOTING (cont.)

Troubleshooting - Table 3

Condition		Check Area	Possible Cause	Remedy
Unit does not operate at all.	LCD displays notification.	KEY LOCKED	Buttons on the control panel are locked.	Press and hold MENU/ESC button for 5 seconds to unlock.
		EXTERNAL THERMOSTAT ACTIVATED	Status is changed to control by an external thermostat.	Operate the unit by an external thermostat. (See page 31.)
	LCD shows normal, but unit does not start.	Set point temperature	Room temperature reached the set point temperature and the unit is stopped.	Adjust the set point temperature.
Air volume change during COOL mode operation.	Fan speed indicates LO but actual speed increase/decrease automatically	Room temperature	Room temperature is lower than 68 °F (20 °C) or greater than 72°F (22 °C) during cooling operation.	Feature to prevent evaporator from freezing.
No low fan speed during HEAT mode operation.	Fan speed LO is automatically changed to MID.	Room temperature	Room temperature is higher than 68 °F (20 °C) during heating operation.	Feature to prevent high pressure protection activation.
No hot air during HEAT mode operation.	LCD display shows HEAT mode, but operates in COOL mode.	Fuse (F1)	Fuse (F1) is blown.	Contact your dealer or a qualified technician.
		Reverse valve	Reverse valve failure	

If conditions persist after the above remedies have been taken, turn the unit off, unplug the power cord from the power supply outlet, and contact your MovinCool dealer or a qualified technician.

TECHNICAL SPECIFICATIONS

Technical Specifications - Table 1

Item		Specifications	
Electronic Features	Operation	Digital Programmable	
Electrical Characteristics	Voltage Requirement	115 V, 1 Phase, 60 Hz	
	Operating Voltage Range	Max.	127 V
		Min.	104 V
Recommended Fuse Size	15 A		
Cooling, Heating Capacity and Power Consumption			
Cooling Performance Rating Condition (AHAM PAC-1-2009) Indoor Heat Exchanger: 80 °F (26.7 °C), 50 %RH Outdoor Heat Exchanger: 80 °F (26.7 °C), 50 %RH	Total Cooling Capacity	10,200 Btu/h (2,980 W)	
	Power Consumption	1.23 kW	
	Current Consumption	11.1 A	
Heating Performance Rating Condition (AHAM RAC-1-2008) Indoor Heat Exchanger: 70 °F (21.1 °C), 56 %RH Outdoor Heat Exchanger: 47 °F (8.3 °C), 73 %RH	Heating Capacity	9,900 Btu/h (2,900 W)	
	Power Consumption	1.25 kW	
	Current Consumption	11.3 A	
Compressor	Type	Hermetic Rotary	
Indoor Heat Exchanger	Type of Heat Exchanger	Plate Fin	
	Type of Fan	Centrifugal Fan	
	Air Flow	High	420 CFM (714 m ³ /h)
		Medium	340 CFM (578 m ³ /h)
		Low	280 CFM (476 m ³ /h)
Max. External Static Pressure	0.31 IWG (77 Pa)		
Outdoor Heat Exchanger	Type of Heat Exchanger	Plate Fin	
	Type of Fan	Centrifugal Fan	
	Air Flow	760 CFM (1,292 m ³ /h)	
Refrigerant	Type	R-410A	
	Amount	1.41 lb (0.64 kg)	
Power Cord	NEMA Plug Configuration	5-15	
	Gauge x Length	14 AWG (3-core) x 10 ft (3.0 m)	
Dimension	W x D x H	21 x 27 x 44 in (533 x 686 x 1,118 mm)	

TECHNICAL SPECIFICATIONS (cont.)

Technical Specifications - Table 2

Item			Specifications
Net Weight			196 lb (89 kg)
Drain Tank Capacity			5.0 gal (19 L)
Cooling Operating Condition Range	Inlet Air Temperature	Max.	95 °F (35 °C), 60 %RH
		Min.	65 °F (18 °C), 50 %RH
Heating Operating Condition Range	Without duct	Max.	80 °F (26.7 °C), 50 %RH
		Min.	40 °F (4.4 °C), 50 %RH
	With duct	Max.	80 °F (26.7 °C), 50 %RH
		Min.	Indoor Heat Exchanger: 40 °F (4.4 °C), 50 %RH Outdoor Heat Exchanger: 24 °F (-4.4 °C), 50 %RH
Maximum Equivalent Duct Length	Indoor Heat Exchanger Duct	30 ft (9.1 m)	
	Outdoor Heat Exchanger Duct	100 ft (30.5 m)	
Sound Level* ¹	With Outdoor Heat Exchanger Duct	High	61 dB (A)
		Low	59 dB (A)
	Without Outdoor Heat Exchanger Duct	High	62 dB (A)
		Low	60 dB (A)

- Specifications are subject to change without notice.

Note:

**1: Measured at 3 feet (1.0 m) away from surface of the unit's front panel.*

MOVINCOOL®

THE #1 SPOT COOLING SOLUTION

WARRANTY STATEMENT

DENSO PRODUCTS AND SERVICES AMERICAS, INC. ("DENSO") warrants its MOVINCOOL Products only to the extent stated in its official written warranties. Unless otherwise specifically provided in writing by DENSO, DENSO warrants to the original end-user that the products shall be free of defects in materials or workmanship and will function in accordance with DENSO's published specifications under ordinary intended use and service for a period listed below beginning from the date of purchase on the invoice to the end-user:

Model: Climate Pro 12

Warranty: 3 Years with warranty registration OR 1 Year for unregistered unit.

DENSO shall, at its sole discretion, repair or replace any defective product covered by this warranty. Such remedy shall be end-user's sole remedy with respect to any particular defect in the products.

This warranty does not cover defects or malfunctions which result from causes beyond DENSO's control, including, without limitation, (i) unusual physical or electrical stress; (ii) accident, neglect, abuse, misuse or other abnormal use; (iii) failure to perform routine maintenance in accordance with DENSO's recommended procedures; (iv) normal wear and tear; (v) repairs or attempted repairs by an unauthorized person; (vi) modifications or alterations to the products; (vii) use with parts or devices not supplied or approved by DENSO; (viii) improper installation or service; (ix) shipping damage to any units or spare parts during shipping. This includes and is not limited to compressors and heat exchangers. This warranty shall extend only to the original end-user and shall be void if any labels or other identifying marks permanently affixed to products when shipped by DENSO are removed, altered, defaced or obliterated.

TO THE EXTENT PERMITTED BY LAW, THIS WARRANTY, AS LIMITED HEREIN, SHALL BE IN LIEU OF AND EXCLUSIVE OF ALL OTHER WARRANTIES, EITHER EXPRESSED OR IMPLIED, ON THE PART OF DENSO PRODUCTS AND SERVICES AMERICAS, INC., OR DENSO CORPORATION, WHETHER ARISING FROM LAW, COURSE OF DEALING, USAGE OF TRADE, OR OTHERWISE, INCLUDING WITHOUT LIMITATION ANY IMPLIED WARRANTY OF MERCHANTABILITY OR FITNESS OF A PARTICULAR PURPOSE OR ANY LIABILITY FOR COMMERCIAL LOSSES BASED UPON NEGLIGENCE OR MANUFACTURER'S STRICT LIABILITY. EXCEPT AS EXPRESSLY PROVIDED HEREIN, NEITHER DENSO PRODUCTS AND SERVICES AMERICAS, INC., NOR DENSO CORPORATION WILL, IN ANY EVENT, BE LIABLE FOR LOST PROFITS, COSTS OF PROCESSING, INJURY, GOODWILL, OR ANY OTHER CONSEQUENTIAL DAMAGES OF ANY KIND ARISING FROM BREACH OF THIS WARRANTY.

DENSO PRODUCTS AND SERVICES AMERICAS, INC. reserves the right to make changes without prior notice. MovinCool®, Office Pro® and SpotCool® are registered trademarks of DENSO Corporation.

PURCHASE DATE: _____

SERIAL NUMBER: _____

DENSO

DENSO PRODUCTS AND SERVICES AMERICAS, INC.

Long Beach, CA 90810

www.movincool.com

P/N: 484007-4090EN

First Issue: September 2015