



AIR CONDITIONING

PORTA TEMP 240/320DX

CAUTION

PLEASE READ THIS LEAFLET CAREFULLY

1. DO NOT APPLY MAINS WATER PRESSURE TO THIS UNIT. WHERE APPROPRIATE, ACCESS TO THE FILLING POINT FOR THE WATER CIRCULATING SYSTEM IS REACHED BY THE REMOVAL OF THE FILLER ACCESS PLATE IN THE ROOM UNIT BACK PANEL.
 2. WHEN REMOVING THE UNIT FROM AN INSTALLATION DISCONNECT WATER QUICK COUPLINGS IN THE ROOM UNIT FIRST.
- INTERNAL ACCESS SHOULD BE RESTRICTED TO CALOREX TRAINED STAFF ONLY.**

BLANK PAGE

WARNING !

This unit **MUST** be transported and operated in the upright position at all times.

1) COMMISSIONING INSTRUCTIONS

As standard, these units are supplied with a NEMA power plug attached to the power supply cord. They require a 208/230volt 1 phase 60Hz supply with the following appropriately protected current rating:-

PAC.240 20 AMPS

PAC.320 30 AMPS

The size of any extension cable that may be used is as follows and must be rated above the fuse size also allowing for voltage drop and be suitable for the environment:

PAC.240 14AWG up to 30 feet
12AWG over 30 feet

PAC.320 10AWG up to 30 feet
8AWG over 30 feet

If the cable is on a "cable drum" then ensure that it is completely unwound; serious complications will occur otherwise.

2) SYSTEM DESCRIPTION.

The system comprises a room unit cooling section, an external heat exchanger and the two are inter-connected by means of flow and return water pipes and an electrical supply to the heat exchanger fan. The room unit is fitted with an automatic condensate disposal pump which discharges the condensate via a small plastic pipe **into the base of the external heat exchanger** and all interconnecting pipes and electrics are enclosed in a flexible plastic sheath. In addition, both ends of each pipe are fitted with "quick connect" couplings that open on coupling but reseal to become water tight on disconnect.

3) AIRFLOW

The angled outlets at the top of the room unit are fitted with air grilles that allow the angle of air outlet to be adjusted vertically and horizontally and, in conjunction with the fan speed control switch, the air velocity and direction can be carefully set up to obtain maximum coverage of the area being cooled without causing drafts. Care should be taken to avoid outlet air being obstructed as this will cause the air to "eddy" around the unit resulting in recirculation and short/inaccurate cycling of the machine. Ideally, cold air should be directed to create a "blanket" all across the ceiling area allowing natural convection to drop the air over the whole area at very low velocity.

4) SITING

Ideally, the room unit should be positioned equidistant along the shortest wall in the room blowing down the length of the room. If there is more than one unit in the same area, then they would normally be positioned side by side, and equidistant along the long wall, all pointing in the same direction. Sometimes it may be necessary to position units around the perimeter of an area but, in this case, great care should be taken to avoid one unit blowing cold air straight into another which will adversely affect the machine operation. Good and correct air flow is, perhaps, the single most important aspect of satisfactorily applying portable air conditioners. If in doubt seek the advice of your supplier.

EXTERNAL HEAT EXCHANGER (HEX).

The heat exchanger must stand external to the area being cooled and, preferably, in the outside atmosphere. It can stand freely on a flat surface or, in the case of the PAC.240 may be hung in the upright position from a window sill, balcony etc, see Fig 1. **USE THE CHAINS PROVIDED TO SUPPORT THE HEAT EXCHANGER. IT WOULD BE HIGHLY DANGEROUS TO SUPPORT THE HEAT EXCHANGER BY MEANS OF THE FLEXIBLE LINES ALONE.**

Fig 1

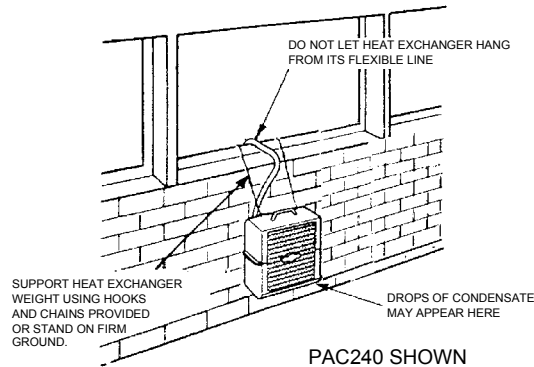

CONDENSATE.

In operation, the room unit is constantly condensing water vapour out of the atmosphere (reducing relative humidity). This water has to be drained away. An automatic condensate pump is fitted inside all room units. The flexible hose outlet from the condensate pump runs to the outside, inside the flexible sheath, the condensate is deposited in the base of the heat exchanger, considerable re-evaporation of this water takes place on the warm air stream passing through and around the heat exchanger, but please remember that there will also be a degree of dripping through the base of the heat exchanger.

HAVE GREAT REGARD FOR THIS CHARACTERISTIC WHEN POSITIONING THE EXTERNAL HEAT EXCHANGER.

The flexible water pipes should be routed so as to avoid any possibility of kinking or unnecessary restrictions to the flow of water inside. Also, remember that plastic and rubber becomes much more flexible when warm and, as a result, much more susceptible to distortion.

5) MACHINE LINK-UP.

Ensure the mains supply lead to the room unit is disconnected. A 5m (extendable to 30m) line set to connect water between the room unit and the external heat exchanger will have been supplied. The water pipe connections are by means of "quick connect couplers". These are simple "push-on" connectors which, when disconnected (after pulling back sprung loaded locking ring), re-seal the water system on either side. The complete system will have been filled with the necessary amount of water/antifreeze prior to its arrival on site. A condensate drain pipe coupler 6mm clear polythene (push fit), should also be connected. Having made the couplings, the system is operational immediately.

6) ROOM UNIT WATER LEVELS.

The water system in the room unit will be to the correct level when delivered. However if for some reason the level has fallen, antifreeze (33%) and water will have to be added. The header tank filler and level indication is located to the rear of the room unit and can be accessed by removing the two screws holding the security plate over the filler tank cap, see Fig 2. Ensure the machine is running in cooling mode before removing the header tank cap, and as with all pressure caps, remove slowly. It is recommended that a mixture, by volume, of one part antifreeze to two parts water is utilised, this will prevent freezing down to an external temperature of -30°C/-5°F. The approximate total volume the systems, room unit with external heat exchanger and lines is as follows:-

Fig 2

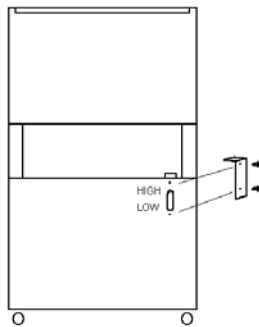

LINESET LENGTH	Total Volume	Units
16FT	2.65	U.S Gallons
21FT	3.07	U.S Gallons
32FT	3.25	U.S Gallons
48FT	3.85	U.S Gallons
64FT	4.45	U.S Gallons
80FT	5.05	U.S Gallons

7) OPERATING INSTRUCTIONS.

The Control Panel on the room unit is illustrated below, see Fig 3.

- Revolve thermostat knob fully CLOCKWISE to the number "8" position.
- Plug in the room unit mains cable, and switch on electricity, red mains light will illuminate.
- Select "Fan Only" with the mode switch. The fan will start.
- Select "Fan Speed", with the fan speed switch, high or low depending on air velocity required.
- Select "Cooling" with the mode switch, and revolve the thermostat knob fully ANTI-CLOCKWISE to the number "1" position. If fitted the external heat exchanger fan and the water pump in the room unit will start. After a delay of 10mins the green "Cooling" light will illuminate and the machine will proceed to cool the air.
- Monitor the room temperature and when it has reduced to the desired level, very slowly revolve the thermostat knob back, clockwise, until the green "Cooling" light goes out. The room unit will now control the room temperature cooling automatically at this setting.

DO NOT APPLY MAINS WATER PRESSURE TO THE SYSTEM.

Fig 3

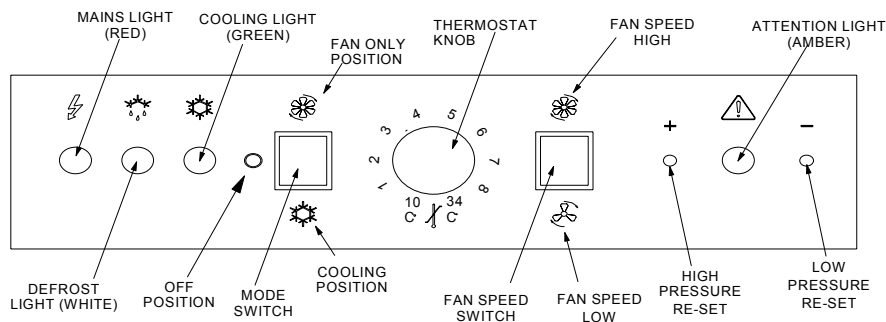

8) ROUTINE MAINTENANCE

The air filter must be kept clean, never allow to become choked with dust or dirt. If allowed to do so, the performance of the unit will become impaired, resulting in loss of air flow, freezing up of the evaporator coil and possible component damage.

ACCESSING THE FILTER

Lift open the return air grille on the front face of the unit, Fig 4. On refitting the filter ensure that it is correctly positioned covering the whole rear face of the grille. The filter (see Fig. 4) can be washed in warm, soapy water, rinsed and shaken dry before replacement. Frequency of cleaning depends upon application and can only be determined by the user. However, you should never allow more than two months to elapse between cleaning. The probable life of the filter will be about one year and spares are available from the supplier of the unit itself. Failure to have filter fitted during operation will cause serious damage.

The refrigeration circuit inside the room unit is fitted with a HIGH and a LOW pressure sensing switch. They are both manually re-settable. A pencil or screwdriver with gentle pressure on the knob behind is all that is required to re-set. Necessary access is provided through the control console. HOWEVER, DO NOT ATTEMPT TO RE-SET WITHOUT FIRST DISCOVERING WHY THE TRIP OCCURRED IN THE FIRST PLACE

FIG 4.

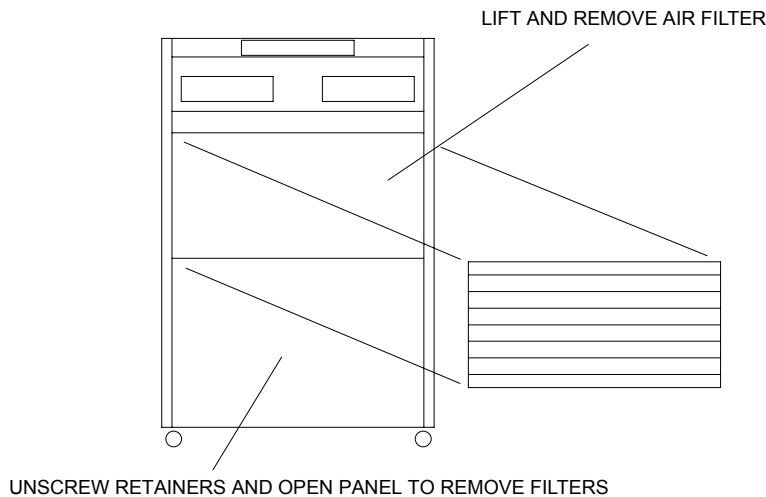

9) MACHINE NOT WORKING?

ONLY A COMPETENT ELECTRICIAN SHOULD ATTEMPT TO RECTIFY ELECTRICAL SUPPLY PROBLEMS. DO NOT REMOVE ANY PANELS FROM THE MACHINE.

Problem - No air flow from room unit.

Diagnosis -Red "MAINS" light off.

Cure - Turn on electricity and/or check mains supply fuse.

Problem - No air flow from room unit.

Diagnosis - Red "MAINS" light on, White "DEFROST" light on.

Cure - Machine in defrost mode, do not adjust anything, machine will revert to normal run after 10 mins.

Problem - Insufficient air flow from room unit.

Diagnosis - Blocked air filter.

Cure - Clean filter

Problem - No cooling.

Diagnosis - Green "COOLING" light off.

Cure - Revolve thermostat knob fully anti-clockwise to "1". Wait 10 minutes for time delay on start-up

Problem - No cooling.

Diagnosis - Amber "ATTENTION" light illuminated. High pressure trip.

Cure - Press "+" button to re-set and check for :- Lack of water flow ... kinked hoses? Shortage of water ... top up.

External heat exchanger unit mounted in very high temperature? Water frozen? Add glycol (33%).

External heat exchanger coil blocked with dirt ... clean.

Problem - No Cooling.

Diagnosis - Amber "ATTENTION" light illuminated. Low pressure trip.

Cure - Press, "-" button to re-set and check for :- No air flow, blocked filter?

Evaporator blocked with ice. Very low external temperature?

Problem - No Cooling.

Diagnosis - Amber "ATTENTION" light illuminated. Low pressure trip.

Cure - Condensate pump not reducing water level. Kink in Condensate tube between room unit and heat exchanger? Leak inside room unit. Sump filter inside room unit blocked. Condensate tube frozen.

DO NOT SCALE PRINT

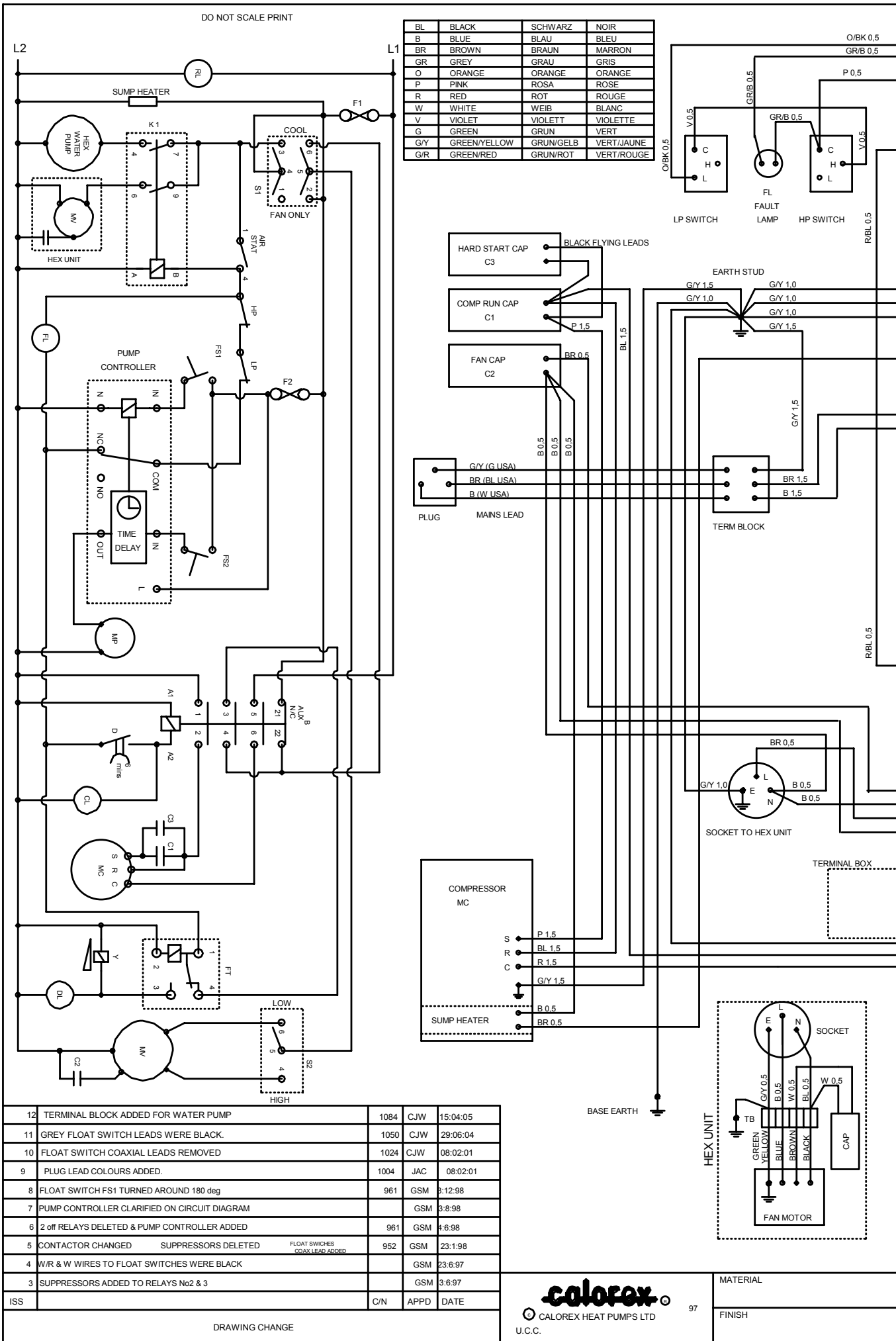

12	TERMINAL BLOCK ADDED FOR WATER PUMP	1084	CJW	15:04:05
11	GREY FLOAT SWITCH LEADS WERE BLACK.	1050	CJW	29:06:04
10	FLOAT SWITCH COAXIAL LEADS REMOVED	1024	CJW	08:02:01
9	PLUG LEAD COLOURS ADDED.	1004	JAC	08:02:01
8	FLOAT SWITCH FS1 TURNED AROUND 180 deg	961	GSM	3:12:98
7	PUMP CONTROLLER CLARIFIED ON CIRCUIT DIAGRAM		GSM	3:8:98
6	2 off RELAYS DELETED & PUMP CONTROLLER ADDED	961	GSM	4:6:98
5	CONTACTOR CHANGED SUPPRESSORS DELETED	952	GSM	23:1:98
4	W/R & W WIRES TO FLOAT SWITCHES WERE BLACK		GSM	23:6:97
3	SUPPRESSORS ADDED TO RELAYS No2 & 3		GSM	3:6:97
ISS		C/N	APPD	DATE

DRAWING CHANGE



MATERIAL	
FINISH	

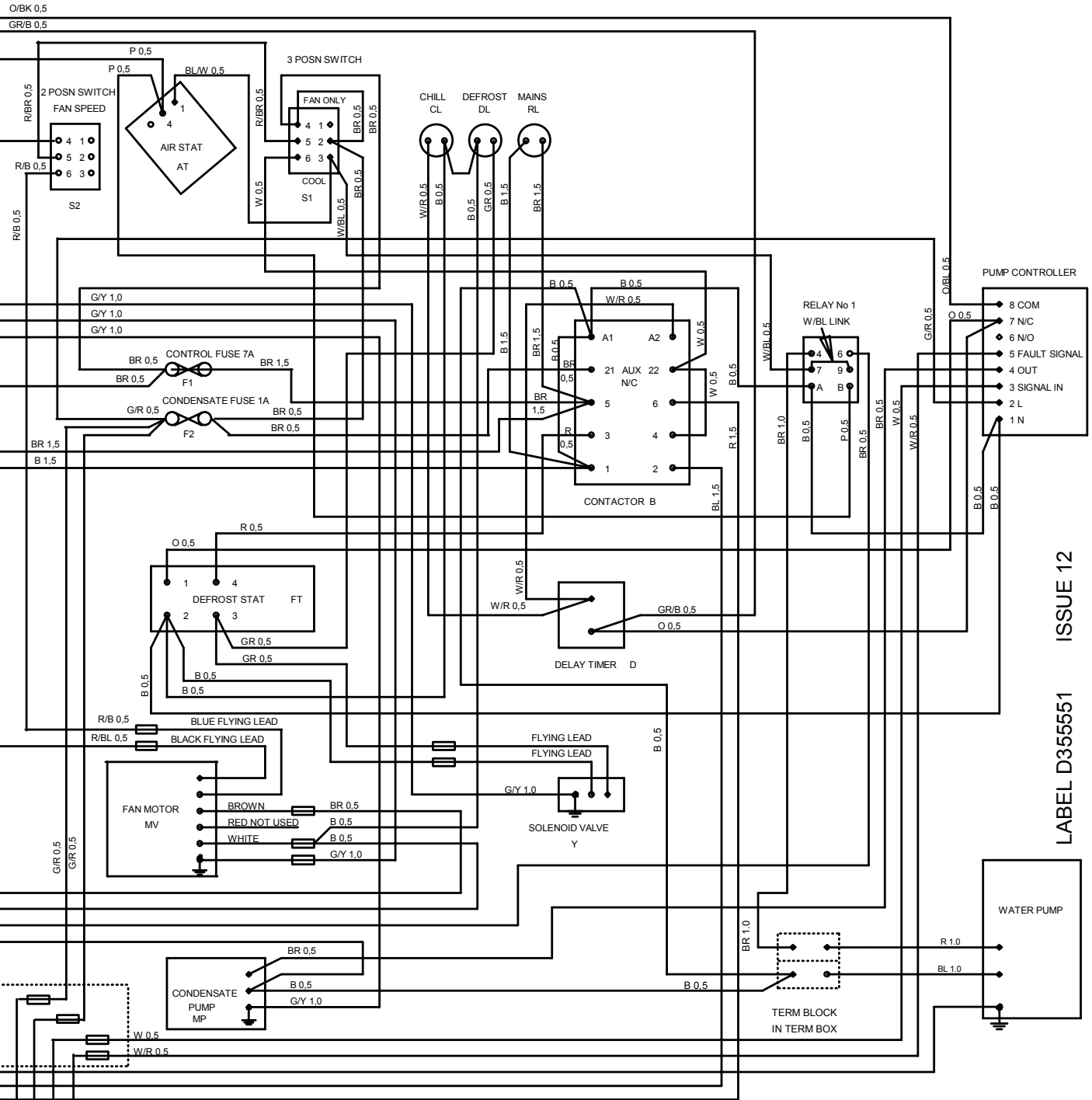

ISSUE 12
LABEL D355551

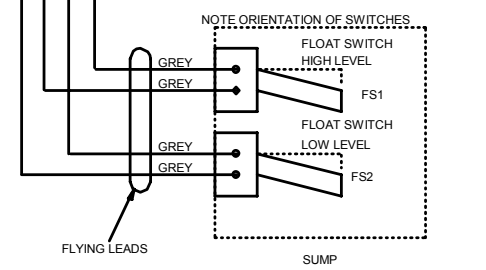

FL	FAULT LAMP	LAMPE 'FEHLER'	VOYANT PANNE
FS1	FLOAT SWITCH HIGH LEVEL	SCHWIMMERSCHALTER HOHER STAND	INTERRUPTEUR A FLOTTEUR NIVEAU HAUT
FS2	FLOAT SWITCH LOW LEVEL	SCHWIMMERSCHALTER NIEDRIGER STAND	INTERRUPTEUR A FLOTTEUR NIVEAU BAS
DL	DEFROST LAMP	LAMPE 'ENTEISEN'	VOYANT DEGIVRAGE
CL	CHILL LAMP	LAMPE 'KUEHLEN'	VOYANT REFRIGERATION
RL	MAINS (OR RUN) LAMP	LAMPE 'STROM EIN' ODER 'LAUF'	VOYANT SECTEUR (FONCTIONNEMENT)
F1	CONTROL FUSE	KONTROLLSICHERUNG	FUSIBLE PRINCIPAL
F2	CONDENSATE FUSE	KONDENSATSICHERUNG	FUSIBLE CONDENSAT
B	CONTACTOR	SCHALTSCHUTZ	CONTACTEUR
FT	DEFROST THERMOSTAT	VEREISUNGSSCHUTZTHERMOSTAT	THERMOSTAT DE DEGIVRAGE
S1	FAN MODE SWITCH	GEBLASESCHALTER	SELECTEUR DE MODE DU VENTILATEUR
S2	FAN SPEED SWITCH	SCHALTER VENTILATORGESCHWINDIGKEIT	COMMUTEUR VITESSE VENTILATEUR
HP	HIGH PRESSURE SWITCH	HOCHDRUCKSCHALTER	REINITIALISATION DEFAUT HAUTE PRESSION
LP	LOW PRESSURE SWITCH	NIEDERDRUCKSCHALTER	REINITIALISATION DEFAUT BASSE PRESSION
D	DELAY TIMER	VERZOGERUNGSRELAIS	TEMPORISATEUR
K	RELAY	RELAIS	RELAIS
MC	COMPRESSOR MOTOR	KOMPRESSORMOTOR	COMPRESSEUR
MV	FAN MOTOR	VENTILATORMOTOR	MOTEUR DU VENTILATEUR
C1	COMPRESSOR CAPACITOR	KONDENSATOR KOMPRESSOR	CONDENSATEUR DU COMPRESSEUR
C2	FAN CAPACITOR	KONDENSATOR VENTILATOR	CONDENSATEUR DU VENTILATEUR
C3	HARD START CAPACITOR	HARTSTARTKONDENSATOR	CONDENSATEUR DEMARRAGE DIRECT
C4	SUPPRESSOR	ENTSTORUNGSELEMENT	SUPPRESSEUR
Y	SOLENOID VALVE	MAGNETVENTIL	VANNE ELECTROMAGNETIQUE
AT	AIR THERMOSTAT	LUFTTHERMOSTAT	THERMOSTAT AIR
MP	CONDENSATE PUMP	KONDENSATPUMPE	POMPE A CONDENSAT

TOLERANCE UNLESS SPECIFIED		TITLE		SHT No.	CONT'	DRAWN	APPROVED	DATE	SCALE
HOLES TO BS 4500 E12		WIRING DIAGRAM		1	---	GSM		9:4:97	NTS
INSPECTION LEVEL		PAC240/HEX240		DRG No.		D355550			
	DIMS								

DO NOT SCALE PRINT

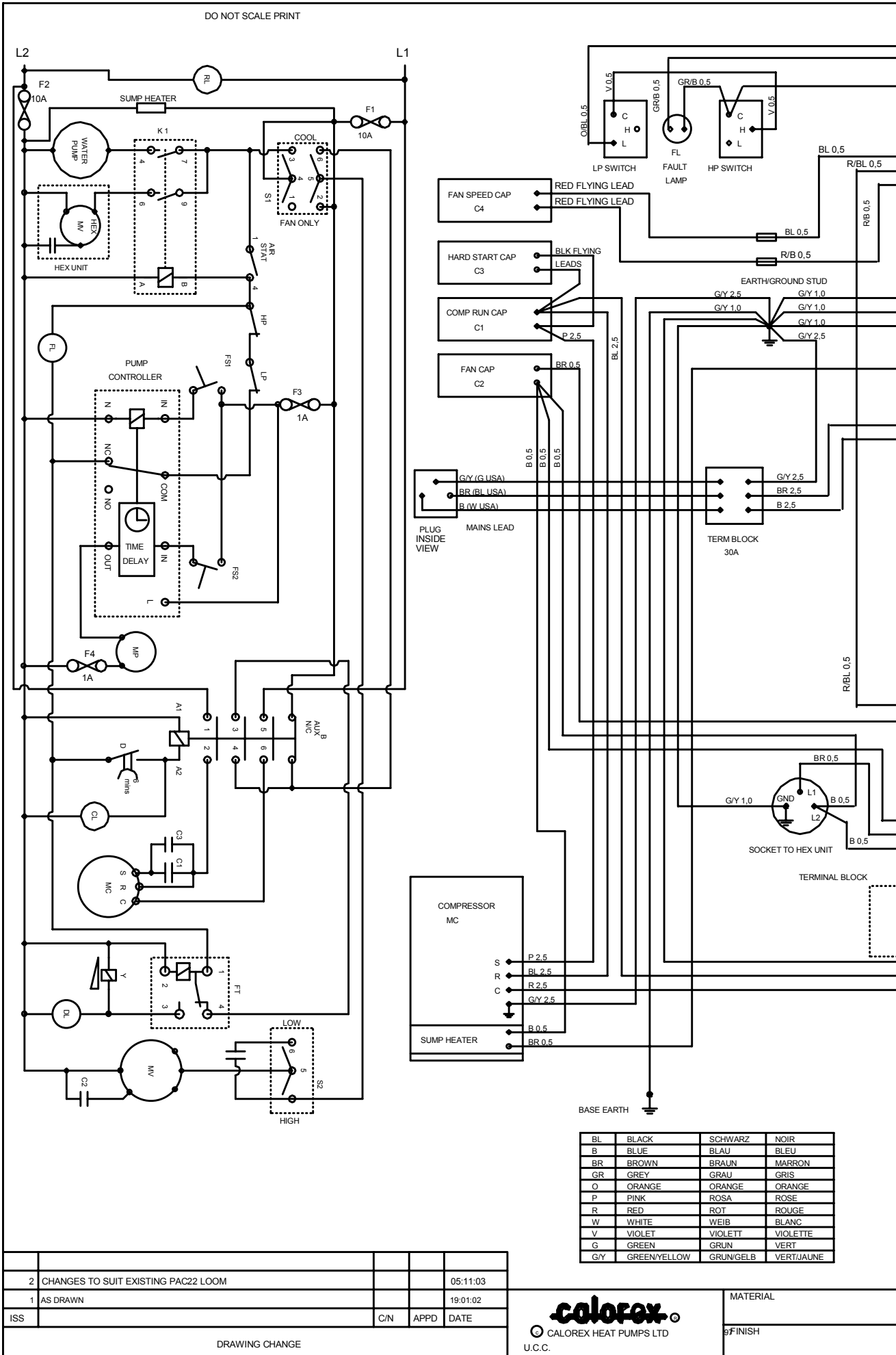

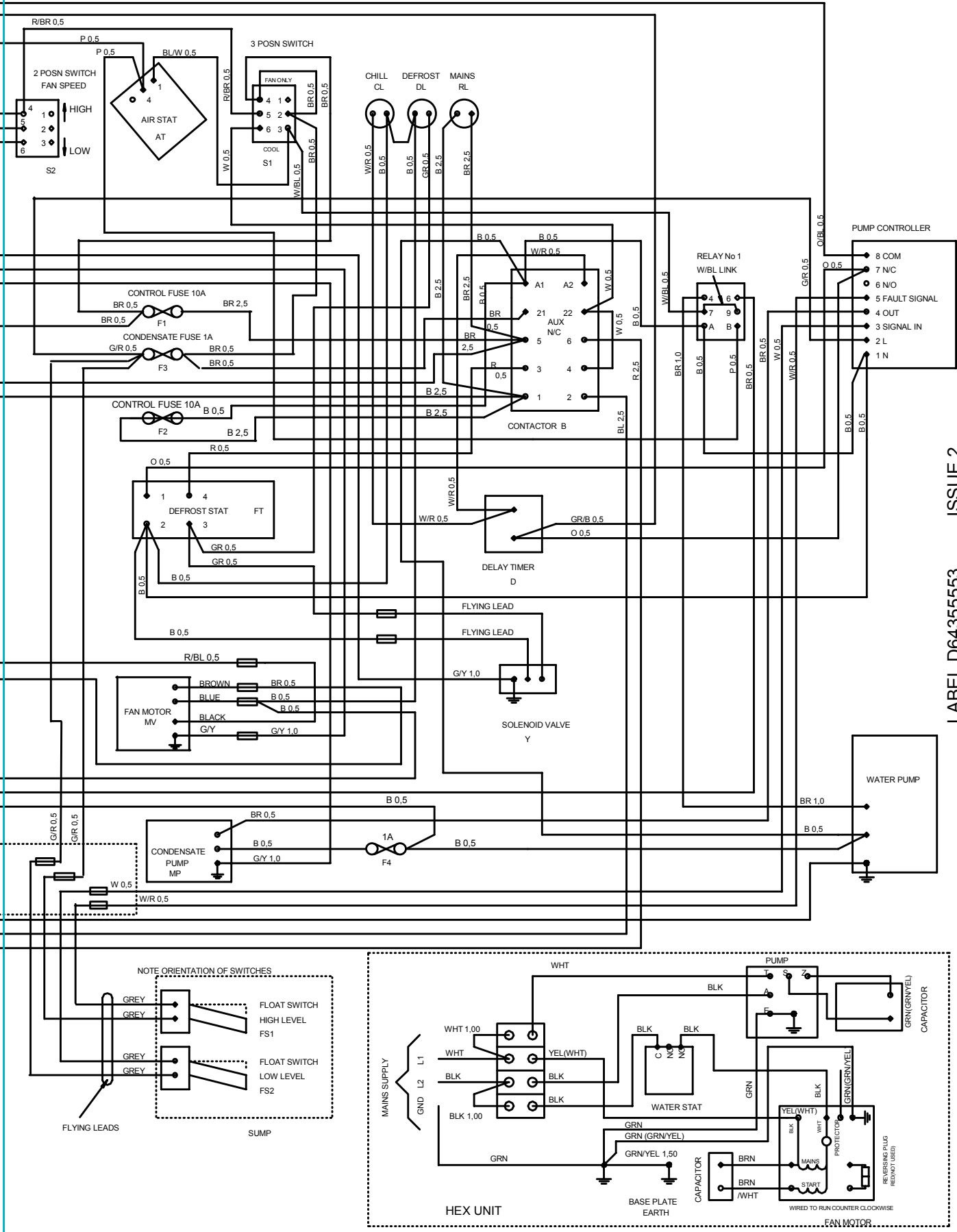

ISSUE 2
LABEL D64355553

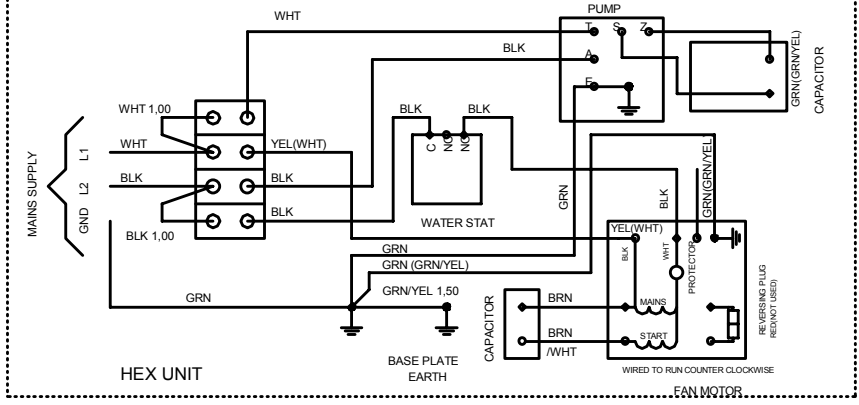
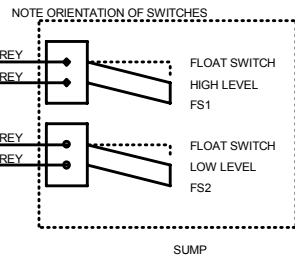

TOLERANCE UNLESS SPECIFIED	
HOLES TO BS 4500 E12	
INSPECTION LEVEL	DIMS

TITLE	WIRING DIAGRAM PAC320DX/HEX320D
-------	------------------------------------

SHT No.	CONT	DRAWN	APPROVED	DATE	SCALE
1	-	CJW		19:01:02	NTS
DRG No. D355552					

BLANK PAGE

BLANK PAGE

BLANK PAGE