

Office Pro 18

Cooling Capacity	Btu/hr. @ 95° At 60% Relative Humidity	16,800
Dimensions	Width (Inches) Depth (Inches) Height (Inches) Weight (Pounds) Shipping Weight	21 27 44 170 201
Electrical Characteristics	Power Supply (Volts) Power Consumption (Kilowatts) Current Consumption (Amperes) Fuse Size (Amperes) NEMA Plug Configuration Min-max Voltage Power Cord Gauge Power Cord Length (Feet)	115/1 1.7 15.6 20 5-20 105 -125 Volt 12AWG (3 Core) 10
Compressor Characteristics	Compressor Type Refrigerant Operating Conditions: Min-max °F	Hermetic Rotary 410A 65°-95°F, 50% RH
Fan Characteristics	Evaporator: Fan Type Air Flow (CFM) High/Low Max. External Static Pressure (Inches Of Water Gauge) Condenser: Fan Type Air Flow (CFM) High/Low Max. External Static Pressure (Inches Of Water Gauge)	Centrifugal 540/500 0.31 Centrifugal 770/710 0.23
Safety Devices	Compressor Overload Relay Fan Motor Protection Anti-freeze Thermostat Automatic Tank Shut-off Condensate Tank Capacity (Gallons) High-pressure Switch Compressor Short-cycle Protection Fan Mode Switch Automatic Restart Thermostat Control Panel Thermostat Control	Yes Yes Yes Yes 5 N/A Yes Yes Yes Yes Programmable Electronic
Miscellaneous Features	Operating Cost Humidity Removed @ 60% RH Accommodates Condensate Pump Sound Level (Db) High/Low Max Evaporator Ducting Length*(Ft.) Max Condenser Ducting Length*(Ft.)	\$0.122 0.97 Yes 61/59 25 100

**subtract 10 Ft. For Every 90° Bend*

800.367.8675 • www.spot-coolers.com

Copyright © 2008 Spot Coolers, Inc. All rights reserved.

Office Pro 18

Power Supply 115 volts 60 hertz 1 phase 15.6 amperes

Width 21 inches

Depth 27 inches

Height 44 inches

Weight (net/shipping) lbs 170/201

All models are backed by a 12-month warranty with 36 months for the compressor.
All coils are treated with an acrylic resin coating for extended life and corrosion resistance.

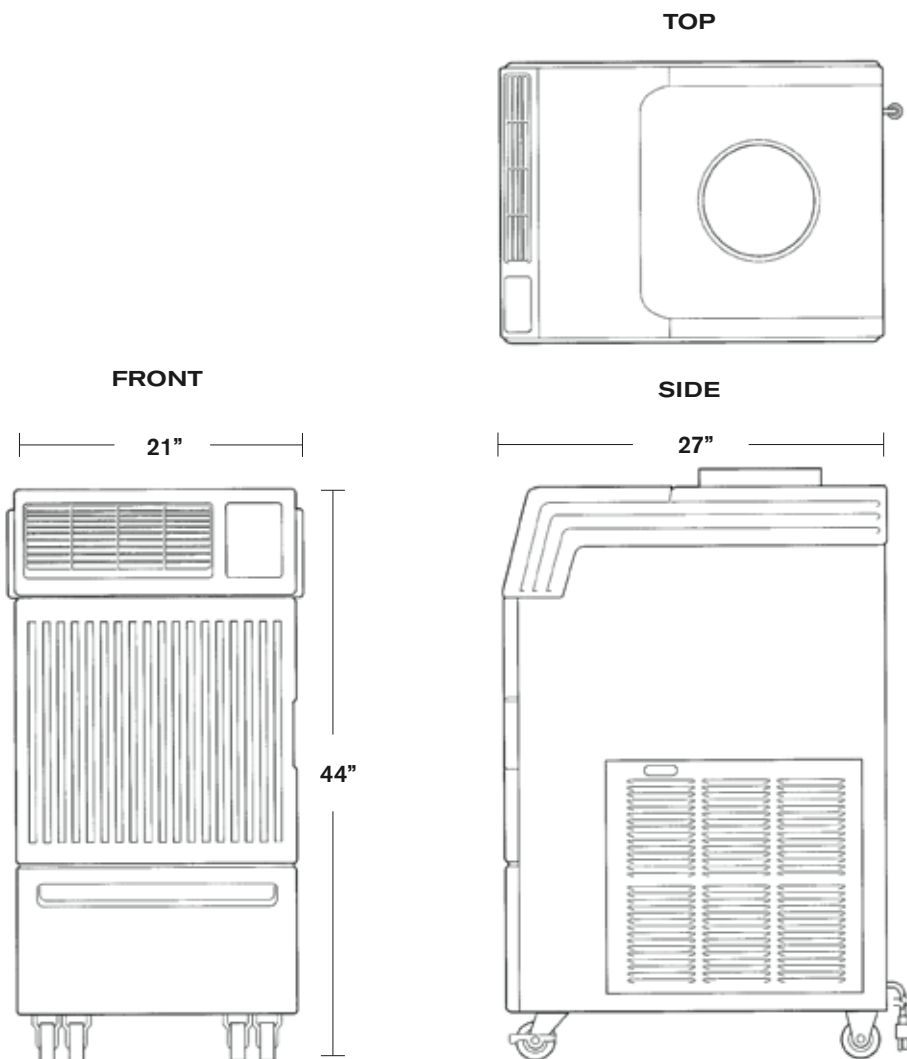

800.367.8675 • www.spot-coolers.com

Copyright © 2008 Spot Coolers, Inc. All rights reserved.

SPOT COOLERS

Office Pro 18

Accessories

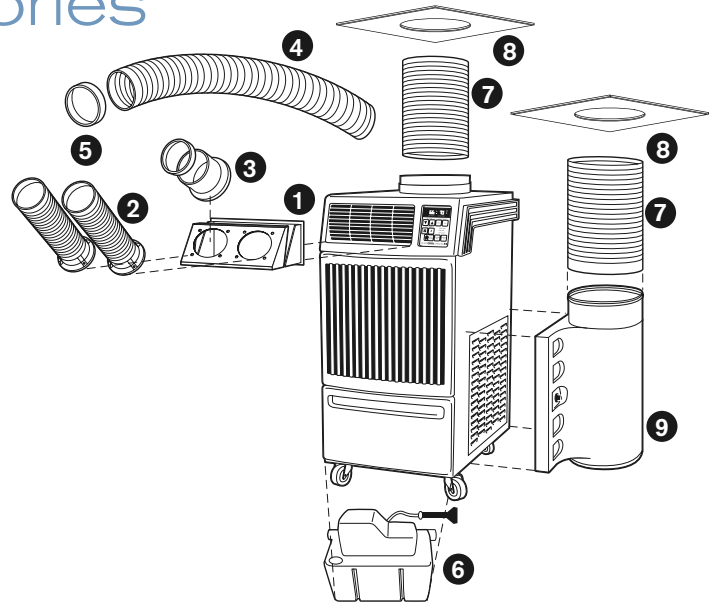
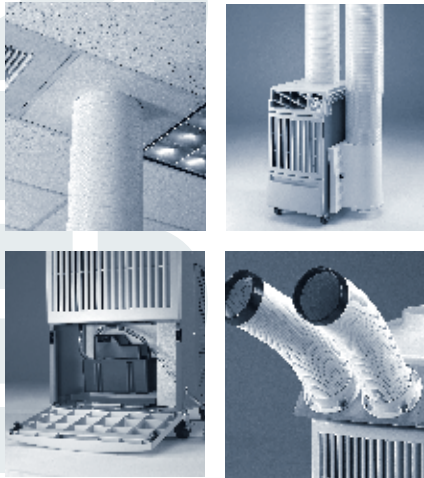

AUTO CONDENSATE REMOVAL

Why bother with emptying the drain tank when you can install a condensate pump to remove the water automatically! This pump has an 18-foot lift capacity to reach virtually any remote drain.

PART NAME

OFFICE PRO 18

Condensate Pump Kit

110V pump kit includes 3/8" diameter x 20' length of hose and installation hardware.

OP18-6

CONDENSER AIR REMOVAL

Removing exhaust is easy. Simply replace the existing ceiling tile with ceiling tile accessory and 12" flexible hose. That's it!

Warm Air Duct

12" diameter white, polypropylene plastic duct that extends 7' in length.

OP18-7

Ceiling Tile

24" x 24" white tile with 12" hole for warm air duct.

OP18-8

MAKE-UP AIR

When balanced air flow is required, attach the air plenum with a duct from the side of the unit to an outside air source. The air to the condenser is pulled from outside the room to eliminate problems associated with negative air pressure.

Air Duct

12" diameter white, polypropylene plastic duct that extends 7' in length.

OP18-7

Ceiling Tile

24" x 24" white tile with 12" hole for warm air duct.

OP18-8

Condenser Air Plenum

White plastic plenum for return air to condenser. Hinged for filter cleaning.

OP18-9

SPOT or REMOTE COOLING

To use the Office Pro to spot cool specific areas, use the nozzle adapter in place of the standard louvers. Attach cold air ducts to the adapter to cool remote hot spots. Trim rings give a finished look and keep the ducts from unraveling.

Nozzle Adapter Kit

Two-piece metal frame converts air-flow from louvers to nozzles or cold air ducts. Includes mounting screws.

OP18-1

Nozzle Kit

5" diameter white plastic duct that extends up to 3.5' in length. Includes flange, mounting screws and trim ring.

OP18-2

Cold Air Flange Kit

5" diameter gray metal flange with wire clamp and mounting screws. Use with cold air ducts.

OP18-3

Cold Air Self-Supported Duct

5" adjustable diameter white polypropylene duct that extends from 6.5' to 10' in length.

OP18-4

Trim Ring

5" diameter black end-cap for cold air self-supported duct.

OP18-5

Office Pro 18

Construction Diagram

All models are backed by a 12-month warranty with 36 months for the compressor.
All coils are treated with an acrylic resin coating for extended life and corrosion resistance.

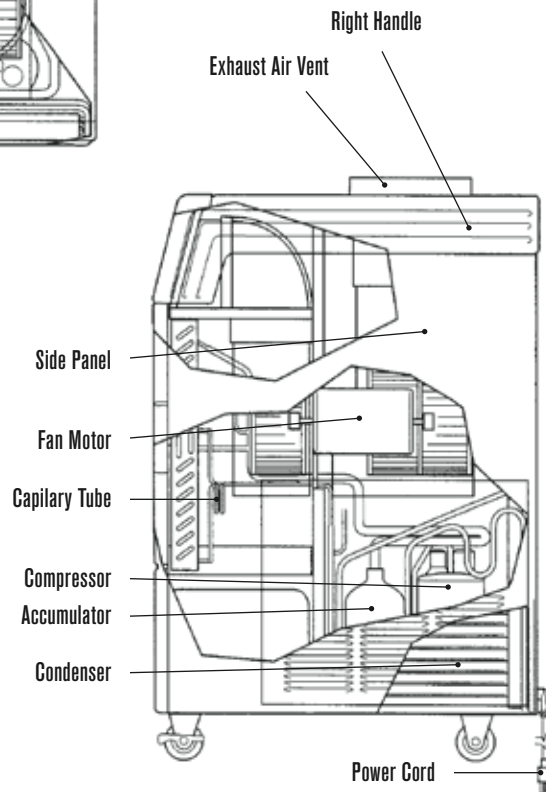
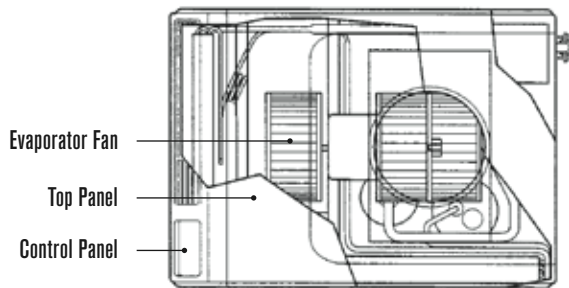
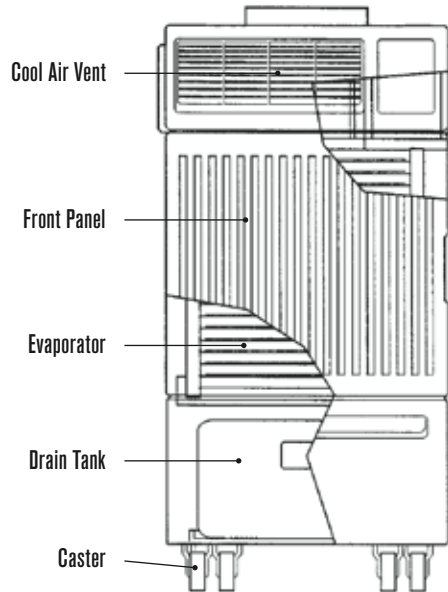

SPOT COOLERS