

# Classic Plus 26

Spot Coolers

<b>Cooling Capacity</b>	Btu/hr. @ 95° At 60% Relative Humidity	24,000
<b>Dimensions</b>	Width (Inches) Depth (Inches) Height (Inches) Weight (Pounds) Shipping Weight	19 29 47 235 265
<b>Electrical Characteristics</b>	Power Supply (Volts) Power Consumption (Kilowatts) Current Consumption (Amperes) Fuse Size (Amperes) NEMA Plug Configuration Min-max Voltage Power Cord Gauge Power Cord Length (Feet)	208/230 1phase 3.1 15.6/14.0 20 6-20 198-250 Volt 12AWG (3 Core) 6
<b>Compressor Characteristics</b>	Compressor Type Refrigerant Operating Conditions: Min-max °F	Hermetic Scroll 22/410A 70°-113°F, 50% RH
<b>Fan Characteristics</b>	<b>Evaporator:</b> Fan Type Air Flow (CFM) High/Low Max. External Static Pressure (Inches Of Water Gauge) <b>Condenser:</b> Fan Type Air Flow (CFM) High/Low Max. External Static Pressure (Inches Of Water Gauge)	Centrifugal 708/600 0.54  Centrifugal 1680/1460 0.25
<b>Safety Devices</b>	Compressor Overload Relay Fan Motor Protection Anti-freeze Thermostat Automatic Tank Shut-off Condensate Tank Capacity (Gallons) High-pressure Switch Compressor Short-cycle Protection Fan Mode Switch Automatic Restart Thermostat Control Panel Thermostat Control	Yes Yes Yes Yes 5 Yes Yes Yes Yes Yes Electronic Electronic
<b>Miscellaneous Features</b>	Operating Cost Humidity Removed @ 60% RH Accommodates Condensate Pump Sound Level (Db) High/Low Max Evaporator Ducting Length*(Ft.) Max Condenser Ducting Length*(Ft.) <i>*subtract 10 Ft. For Every 90° Bend</i>	\$0.223 1.38 Yes 66/64 60 45

800.367.8675 • [www.spot-coolers.com](http://www.spot-coolers.com)

Copyright © 2008 Spot Coolers, Inc. All rights reserved.

# Classic Plus 26

**Power Supply** 208/230 volts 60 hertz 1 phase 15.6 amperes

**Width** 19 inches

**Depth** 29 inches

**Height** 47 inches

**Weight** (net/shipping) lbs 235/265

All models are backed by a 12-month warranty with 36 months for the compressor.  
All coils are treated with an acrylic resin coating for extended life and corrosion resistance.

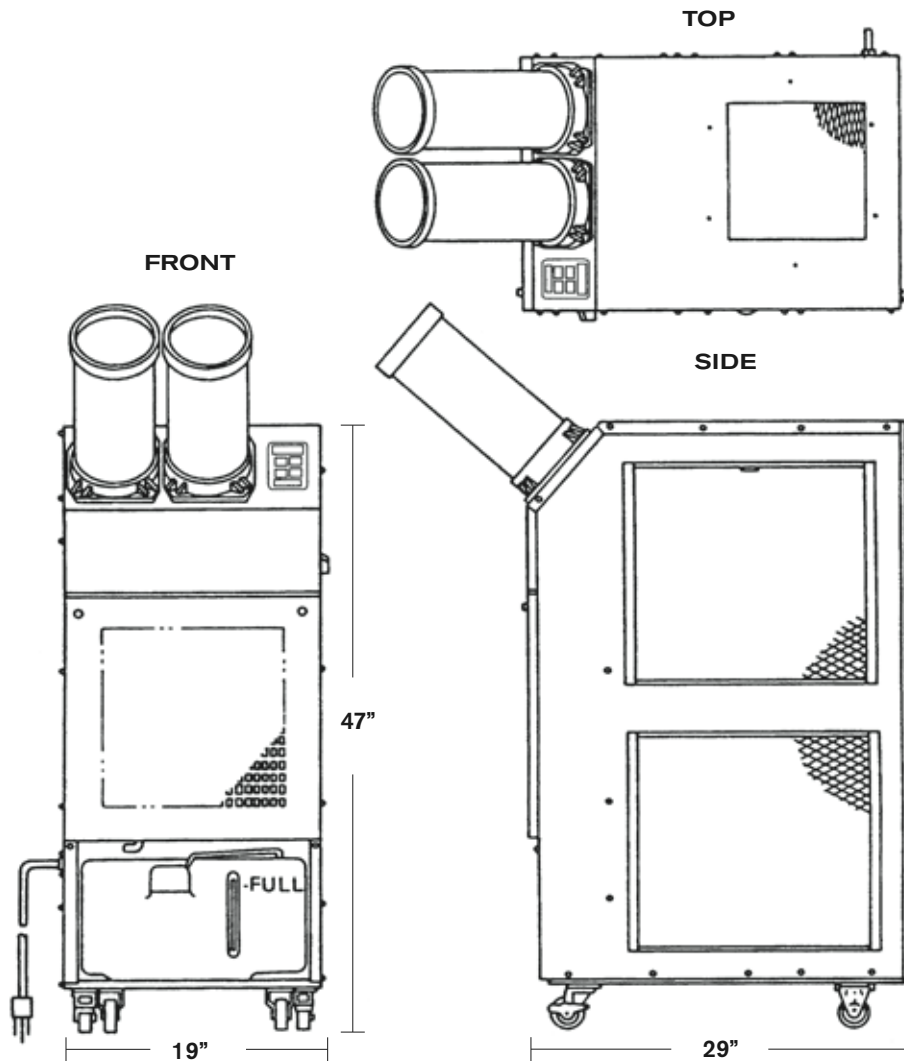

**800.367.8675 • [www.spot-coolers.com](http://www.spot-coolers.com)**

Copyright © 2008 Spot Coolers, Inc. All rights reserved.

Spot Coolers

# Classic Plus 26

## Accessories

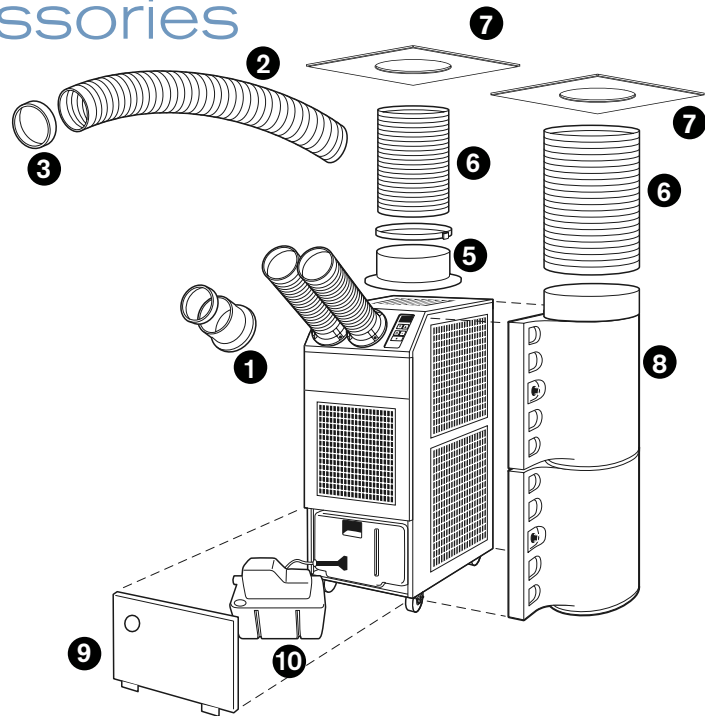

### AUTO CONDENSATE REMOVAL

Why bother with emptying the drain tank when you can install a condensate pump to remove the water automatically! This pump has an 18-foot lift capacity to reach virtually any remote drain.

### CONDENSER AIR REMOVAL

To exhaust the warm condenser air above the work area, attach the warm air flange and duct to the top of the unit. When inside an office, simply replace the ceiling tile with the unit ceiling tile and exhaust the warm air. No special tools or equipment are required for the installation.

### MAKE-UP AIR

When balanced air flow is required, attach the air plenum with a duct from the side of the unit to an outside air source. The air to the condenser is pulled from outside the room to eliminate problems associated with negative air pressure.

### SPOT or REMOTE COOLING

The amount of air supplied to remote areas can be quickly and conveniently increased by attaching 10' extension ducts directly over the standard ducts. For more permanent installations, use the flange and clamp to secure the extension ducts to the unit.

#### PART NAME

#### CLASSIC PLUS 26

<b>Cover Plate</b> Blue metal plate covers condensate collection area.	<b>CP26-9</b>
<b>Condensate Pump Kit</b> 220V pump kit includes 3/8" diameter x 20' length of hose and installation hardware.	<b>CP26-10</b>
<b>Warm Air Flange Kit</b> 12" diameter gray metal flange with wire clamp and mounting screws.	<b>CP26-5</b>
<b>Warm Air Duct</b> 12" diameter white plastic duct extends 7' in length.	<b>CP26-6</b>
<b>Ceiling Tile</b> 24" x 24" white tile with 12" hole for warm air duct.	<b>CP26-7</b>
<b>Air Duct</b> 12" diameter white plastic duct extends 7' in length.	<b>CP26-6</b>
<b>Ceiling Tile</b> 24" x 24" white tile with 12" hole for warm air duct.	<b>CP26-7</b>
<b>Air Plenum</b> White plastic plenum, hinged for filter cleaning.	<b>CP26-8</b>
<b>Cold Air Flange Kit</b> 6" diameter gray metal flange with wire clamp and mounting screws.	<b>CP26-1</b>
<b>Extension Duct</b> 6" diameter white plastic duct that extends from 6.5' to 10' in length.	<b>CP26-2</b>
<b>Trim Ring</b> 6" diameter black plastic ring mounts as end caps for extension ducts.	<b>CP26-3</b>

# Classic Plus 26

## Construction Diagram

All models are backed by a 12-month warranty with 36 months for the compressor.

All coils are treated with an acrylic resin coating for extended life and corrosion resistance.

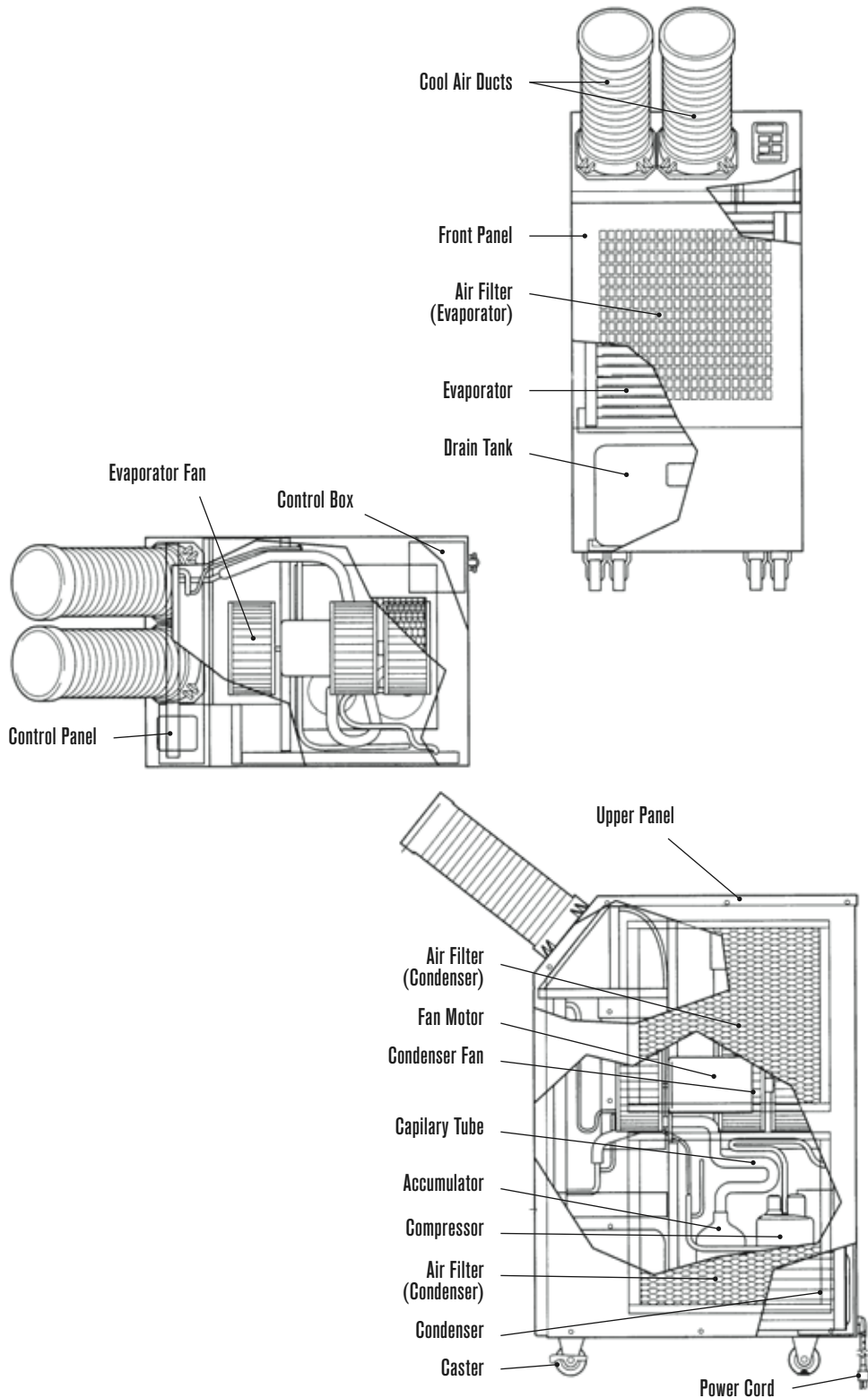

SPOT COOLERS