

SERVICE MANUAL

CLASSIC PLUS 26

SERIAL NUMBER FROM APRIL 2007 (0407) TO DECEMBER 2008 (1208)

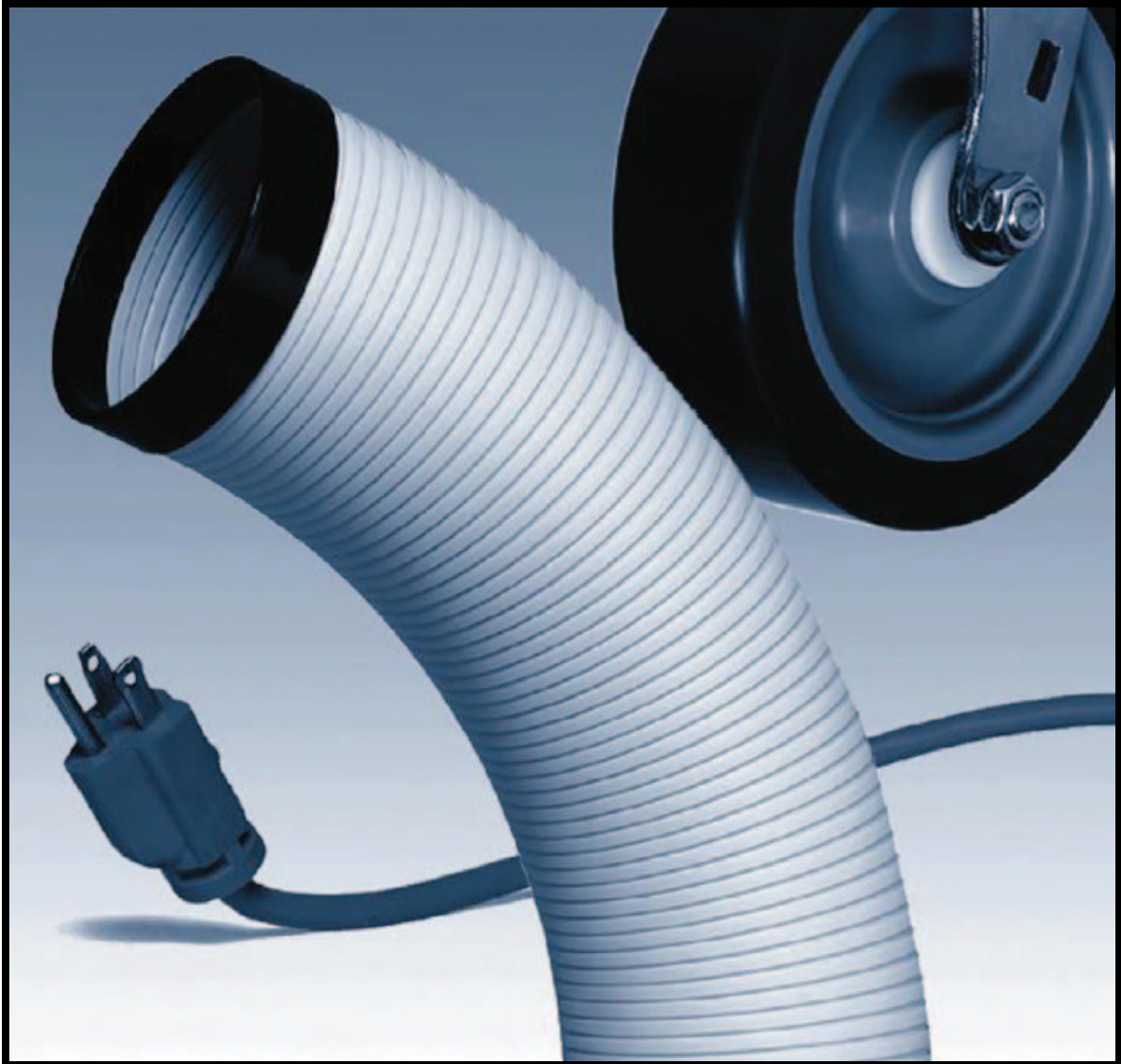

MOVINCOOL®
THE #1 SPOT COOLING SOLUTION

© 2008 DENSO SALES CALIFORNIA, INC.

All rights reserved. This book may not be reproduced or copied, in whole or in part, without the written permission of the publisher. DENSO SALES CALIFORNIA, INC. reserves the right to make changes without prior notice. MovinCool is a registered trademark of DENSO Corporation.

Table of Contents

Operation Section

1. PRECAUTIONS FOR SAFETY

1.1	Foreword.	6
1.2	Definition of Terms	6
1.3	General Precautions.	6

2. GENERAL DESCRIPTION

2.1	Spot Cooler.	7
2.2	Compact Design	7
2.3	Easy Transportation and Installation.	7
2.4	Energy Conservation	7

3. CONSTRUCTION

3.1	Exterior Dimensions	8
3.2	Exterior Components	9
3.3	Internal Structure	10
3.4	Basic Construction	10
3.5	Air Flow.	11
3.6	Compressor and Fans	11
3.7	Drain Tank.	11

4. SPECIFICATIONS

4.1	Technical Specifications	12
4.2	Characteristics (at 230 V).	14
4.3	Characteristics (at 208 V).	15

5. REFRIGERANT SYSTEM

5.1	Refrigerant System Construction	16
5.2	Compressor	17
5.3	Condenser	18
5.4	Capillary Tube.	18
5.5	Evaporator	18
5.6	High Pressure Switch	18
5.7	Modulating Tank	19

6. ELECTRICAL SYSTEM

6.1	Circuit Diagram and Control Box	20
6.2	Basic Operation of The Classic Plus 26 Electrical Circuit.	21

6.3	Control Box	22
6.4	Fan Motor	24
6.5	Compressor Motor	24
6.6	Power Cord with LCDI	25
6.7	Drain Switch	26
6.8	Condensate Pump Kit (optional)	27
6.9	Automatic Restart after Power Interruption.	27
6.10	Compressor Protection.	27
6.11	Temperature Control.	27
6.12	Fan Mode Control Switch	28
6.13	Temperature Scale Display Switch	28

Repair Section

7. TROUBLESHOOTING

7.1	Troubleshooting	29
7.2	Self-Diagnostic Codes	30
7.3	Troubleshooting Chart	32
7.4	Basic Inspection	37

8. DISASSEMBLY

8.1	Parts Construction	39
8.2	Disassembly	40
8.3	Removal of Electrical Parts	42
8.4	Removal of Blower Assembly	46
8.5	Inspection of Capacitor (for Fan Motor and Compressor)	48
8.6	Inspection of Drain Switch	48
8.7	Inspection of Fan Motor	49
8.8	Inspection of Compressor Motor	49
8.9	Inspection of Wiring Connection	49
8.10	Inspection of Thermistor	49
8.11	Inspection	50

9. REFRIGERANT SYSTEM REPAIR

9.1	Repair of Refrigerant System	51
9.2	Removal of Refrigeration Cycle Components	53
9.3	Charging the System with R-22 Refrigerant	54
9.4	Refrigerant Charging Work	59

10. REASSEMBLY



10.1	Removal of Unit	61
10.2	Compressor Mounting	61
10.3	Blower Assembly	61
10.4	Wiring Notice	61
10.5	Perform the Inspection	62
10.6	Caster Maintenance	62
10.7	Schematic	63

1. PRECAUTIONS FOR SAFETY

1.1 Foreword

- This manual has been published to service the MovinCool Classic Plus 26. Please use this service manual only when servicing the Classic Plus 26.

1.2 Definition of Terms

 WARNING	Describes precautions that should be observed in order to prevent injury to the user during installation or unit operation.
 CAUTION	Describes precautions that should be observed in order to prevent damage to the unit or its components, which may occur during installation or unit operation if sufficient care is not taken.
NOTE	Provides additional information that facilitates installation or unit operation.

1.3 General Precautions

WARNING

- **All electrical work if necessary, should only be performed by qualified electrical personnel. Repair to electrical components by non-certified technicians may result in personal injury and/or damage to the unit. All electrical components replaced must be genuine MovinCool parts, purchased from an authorized reseller.**
 - **When handling refrigerant, always wear proper eye protection and do not allow the refrigerant to come in contact with your skin.**
 - **Do not expose refrigerant to an open flame.**
 - **The proper electrical outlet for MovinCool units must be equipped with a “UL” approved ground-fault breaker to prevent electrical shock from the unit.**
 - **When brazing any tubing, always wear eye protection, and work only in a well ventilated area.**
 - **Disconnect power before servicing unit.**
 - **Be careful of any sharp edges when working on unit.**
-

2. GENERAL DESCRIPTION

2.1 Spot Cooler

- In general, conventional air conditioners cool the entire enclosed environment. They act as “heat exchangers”, requiring an interior unit (evaporator) to blow cool air into the interior and an exterior unit (condenser) to exhaust exchanged heat to the outdoors.
- Unlike conventional air conditioners, the MovinCool Classic Plus 26 is a spot cooler which directs cool air to particular areas or objects. MovinCool Classic Plus 26 has the following features:

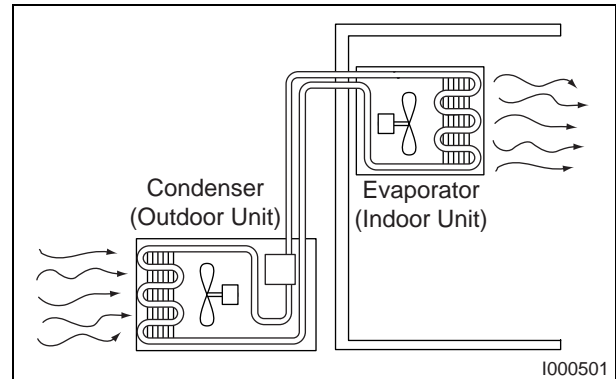

2.2 Compact Design

- The innovative design of MovinCool Classic Plus 26 has resulted in one compact unit, replacing the need for two separate units.

2.3 Easy Transportation and Installation

- With the whole cooling system built into one compact unit, MovinCool Classic Plus 26 requires no piping and can be easily transported and installed.

2.4 Energy Conservation

- MovinCool Classic Plus 26 is economical because it cools only the area or objects which need to be cooled.

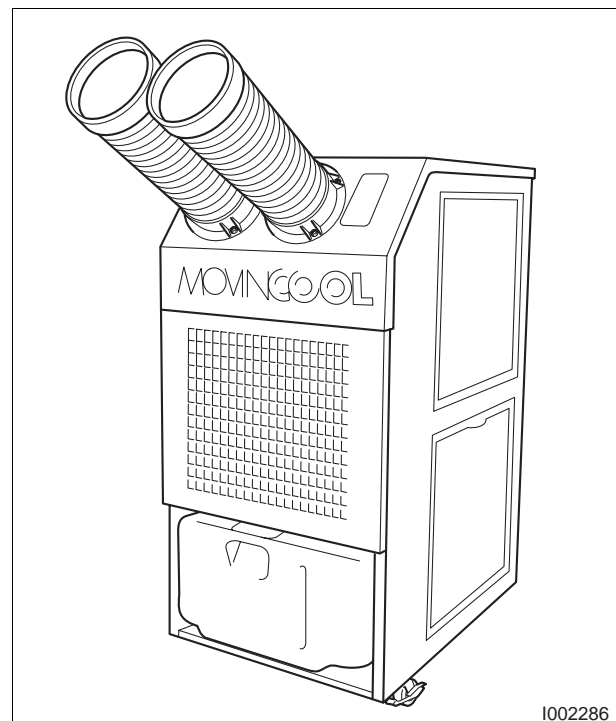

3. CONSTRUCTION

3.1 Exterior Dimensions

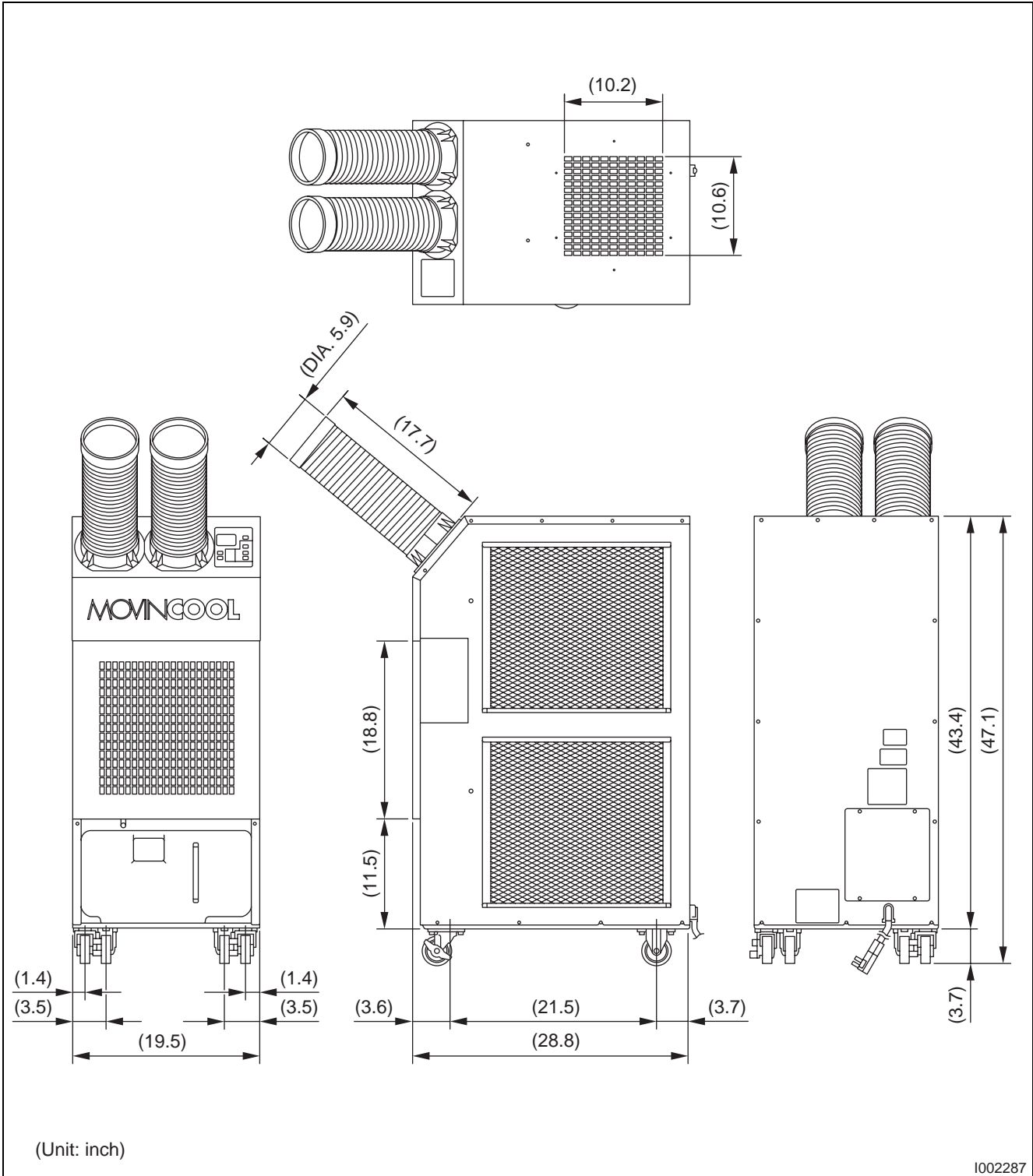

3.2 Exterior Components

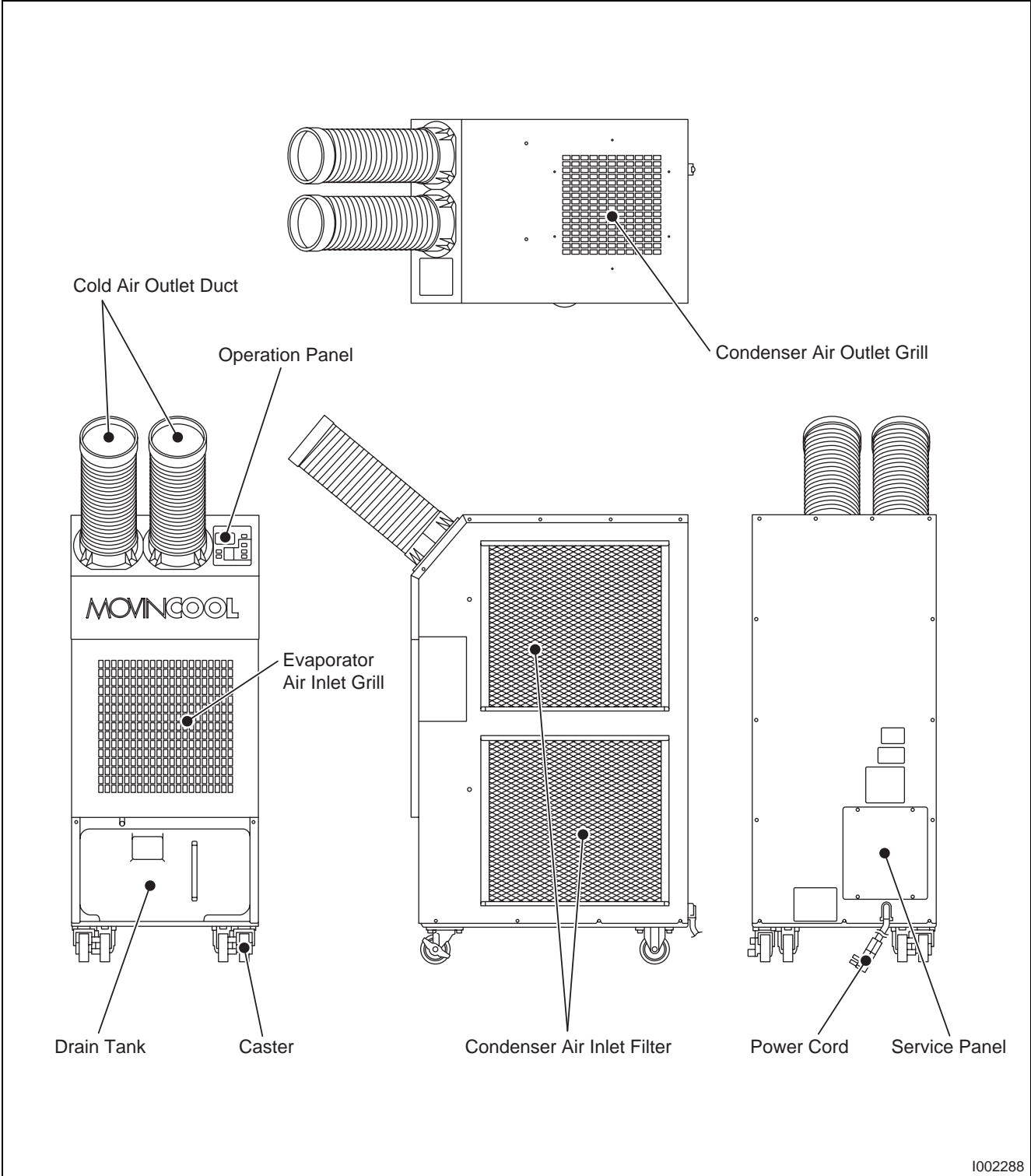

3.3 Internal Structure

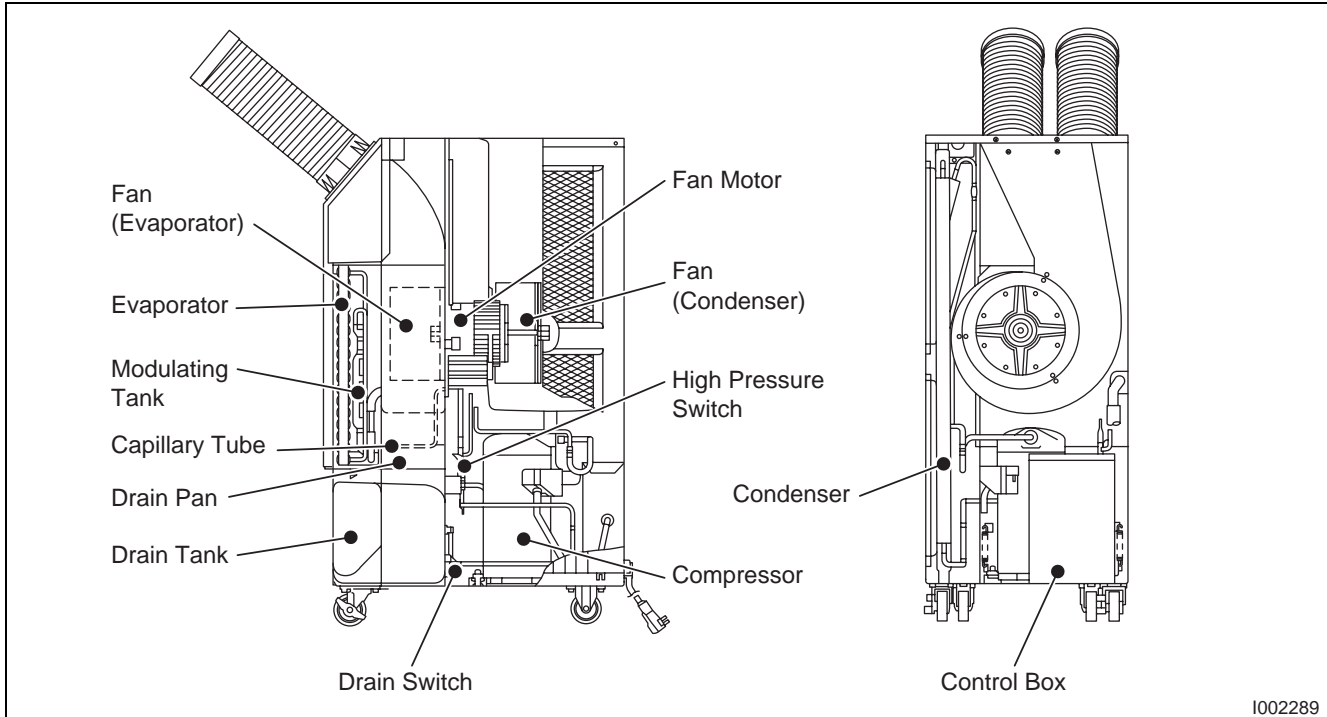

3.4 Basic Construction

- The MovinCool Classic Plus 26 is compact in construction because the condenser and the evaporator are enclosed in one unit. The interior is divided into three sections. The upper front face is equipped with the evaporator, and the lower front face contains the drain tank and condensate pump (Optional). The rear section contains the condenser, the compressor and the control box.

3.5 Air Flow

- Air drawn from the right side face passes through the condenser which extracts the heat. This hot air is blown out through the upper exhaust air duct. Air taken in from the front face is cooled by the evaporator and then blown through the cool air ducts. All the air inlets are equipped with filters, and the exhaust air duct is protected by metal grill.

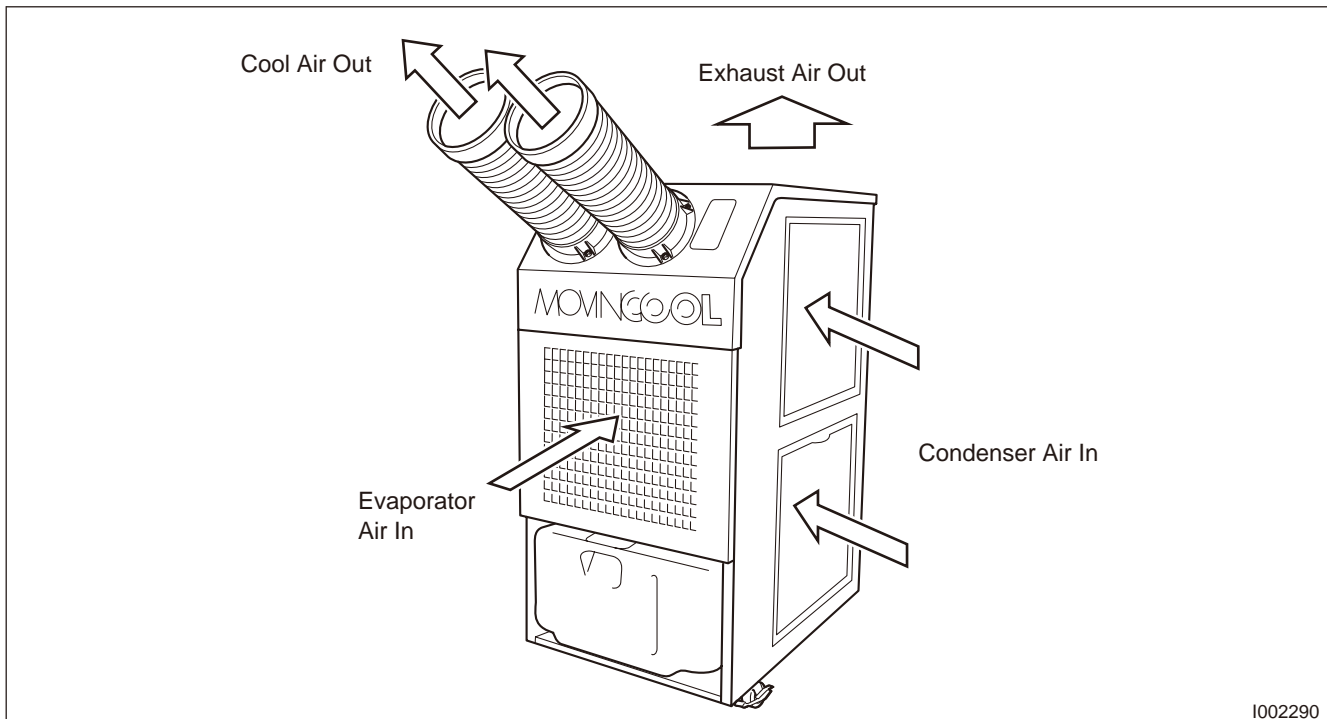

3.6 Compressor and Fans

- The compressor is hermetically sealed. A two-speed fan motor with two centrifugal fans are used to draw air across the evaporator and condenser.

3.7 Drain Tank

- A 5.0 gal (19 L) drain tank is supplied with the Classic Plus 26. The condensate (water) is collected into the tank.

The drain switch activates and stops the operation when tank reaches the level of approximately 4.0 gal (15 L).

4. SPECIFICATIONS

4.1 Technical Specifications

ITEM		SPECIFICATIONS	
Electronic Features	Control Panel	Electronic	
	Thermostat Control	Electronic	
Cooling Capacity* ¹	Capacity-208/230 V	24000/24000 Btu/h (7034/7034 W)	
Refrigerant Circuit	Compressor	Compression Type	Hermetic Scroll
		Motor Rated Output at 230 V	1.60 kW
	Evaporator		Spine Fin
	Condenser		Spine Fin
	Refrigerant Control		Capillary Tube
Refrigerant/Enclosed quantity		R-22/1.87 lb (0.85 kg)	
Ventilation Equipment For Evaporator	Fan Type		Centrifugal
	Max. Air Flow-high/low		708/600 CFM (1200/1020 m ³ /h)
	Motor Rated Output-high/low at 230 V		0.55/0.38 kW
	Max. External Static Pressure		0.54 IWG (134 Pa)
Ventilation Equipment For Condenser	Fan Type		Centrifugal
	Max. Air Flow - high/low		1680/1460 CFM (2850/2480 m ³ /h)
	Motor Rated Output-high/low at 230 V		–
	Max. External Static Pressure		0.25 IWG (62 Pa)
Electronic Characteristics	Power Requirement		208/230 V, 1 PH 60 Hz
	MIN. MAX. Voltage		MIN 198 V, MAX 253 V
	Current Consumption-208/230 V* ¹		16.0/14.6 A
	Total Power Consumption-208/230 V* ¹		3.1/3.1 kW
	Power Factor-208/230 V* ¹		93/92 %
	Starting Current		62 A
Recommended Fuse size		20 A	
Power Cord	NEMA Plug Configuration		6-20
	Gauge x Length		12 AWG (3-core) x 6 ft
Net weight		235 lb (107 kg)	
Operating Condition	Inlet air: Maximum		113 °F (45 °C), 50 %RH
	Inlet air: Minimum		77 °F (25 °C), 50 %RH
Sound Level* ²	With Condenser Duct-high/low		66/64 dB (A)
	Without Condenser Duct-high/low		69/67 dB (A)
Max. Duct Equivalent Length-Per Cold Duct Hose/Hot Duct Hose		60/45 ft (18.3/13.7 m)	

ITEM	SPECIFICATIONS
Condensate Tank Capacity	5 ± 0.5 gal (19 ± 2 L)

- Specifications are subject to change without notice.

< NOTE >

*1 : Rating Condition: 95 °F (35 °C), 60 %RH
*2 : Measured at 3.28 ft (1 m) from surface of unit.

4.2 Characteristics (at 230 V)

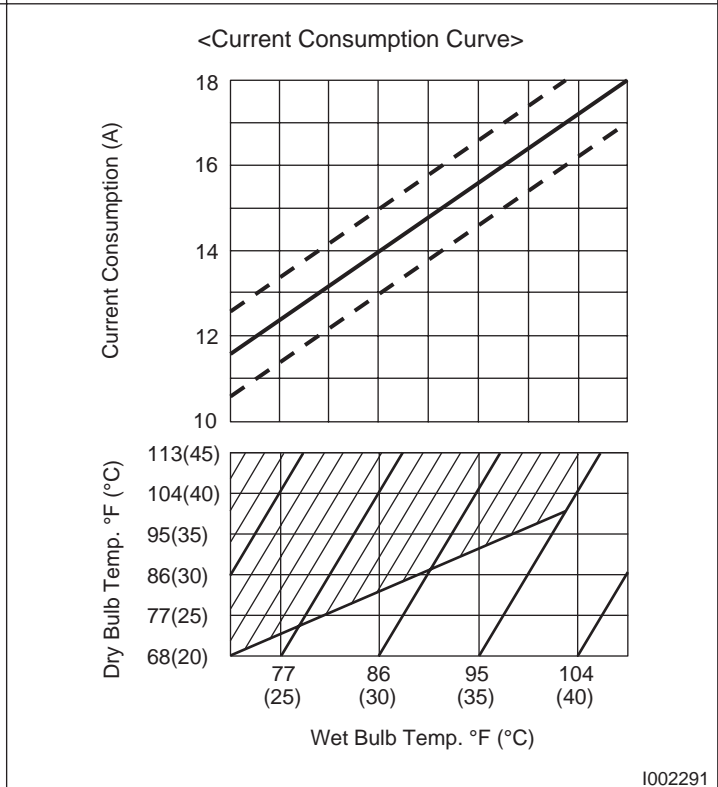
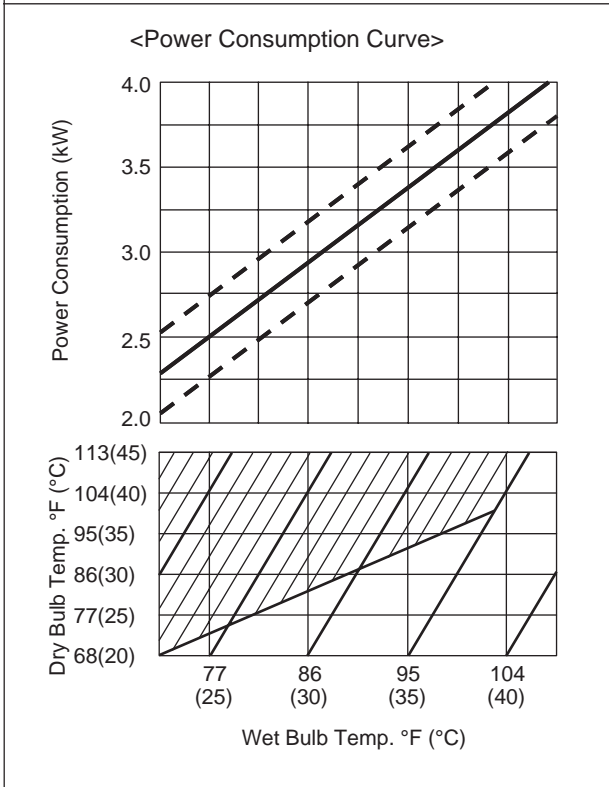
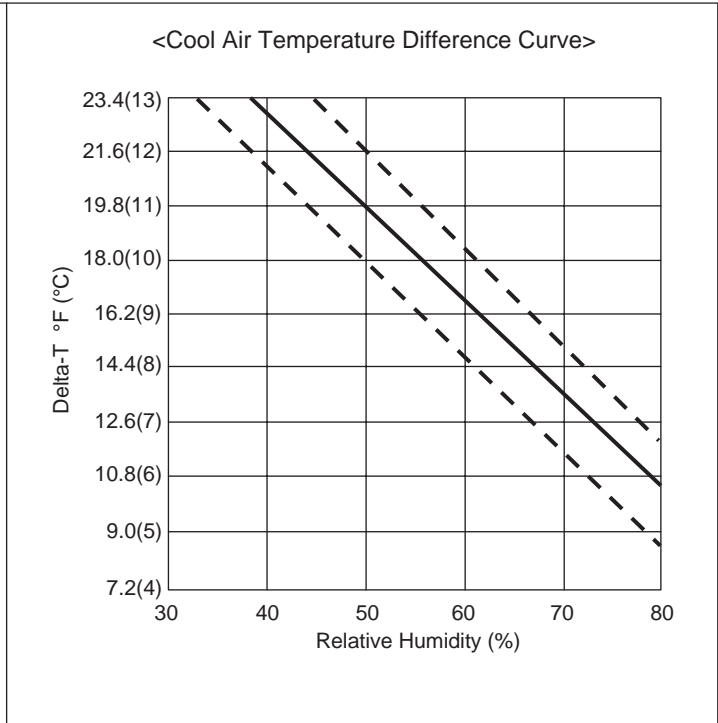
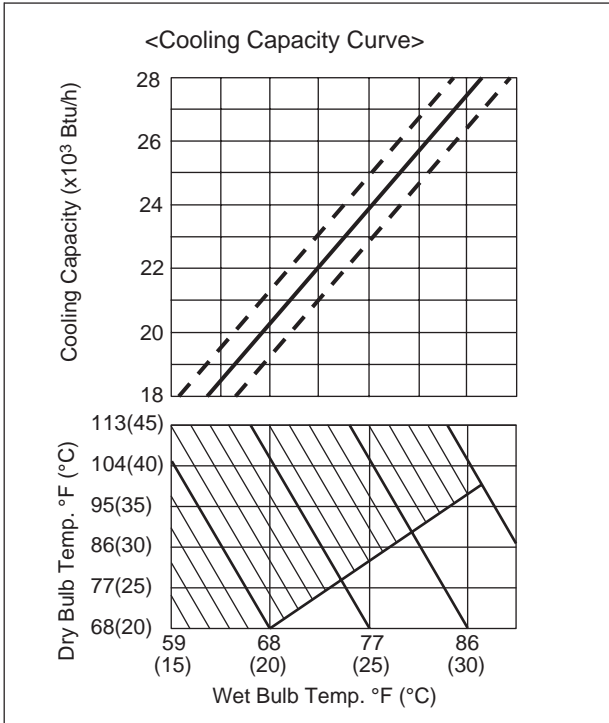

4.3 Characteristics (at 208 V)

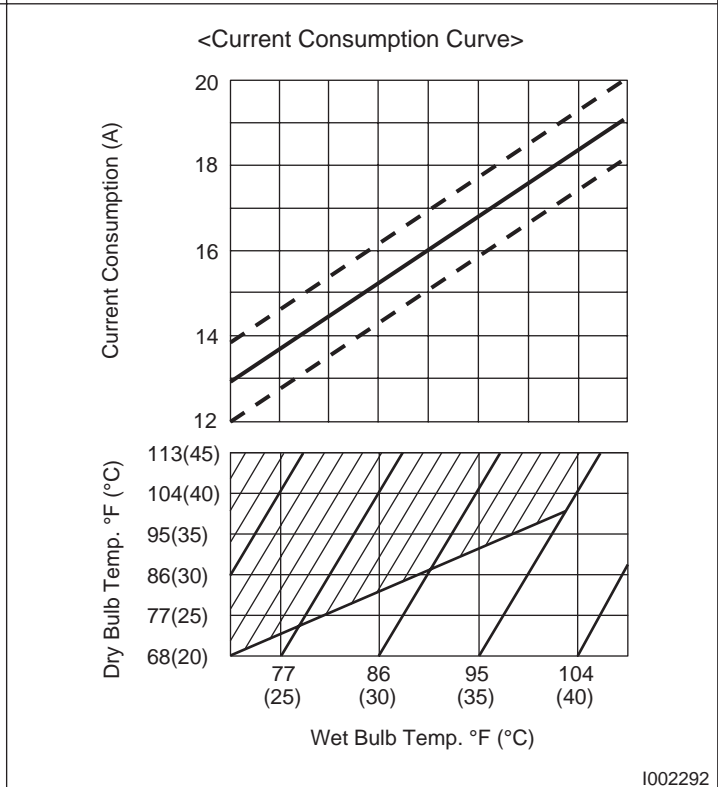
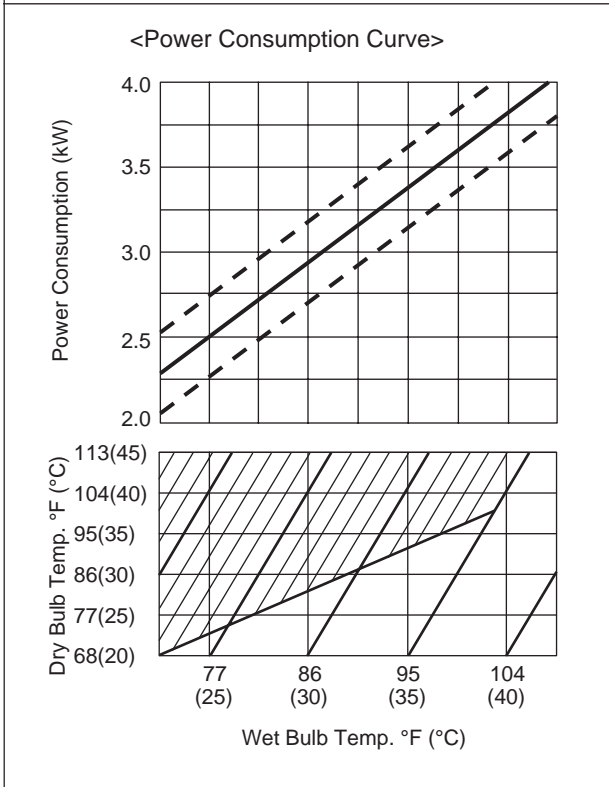
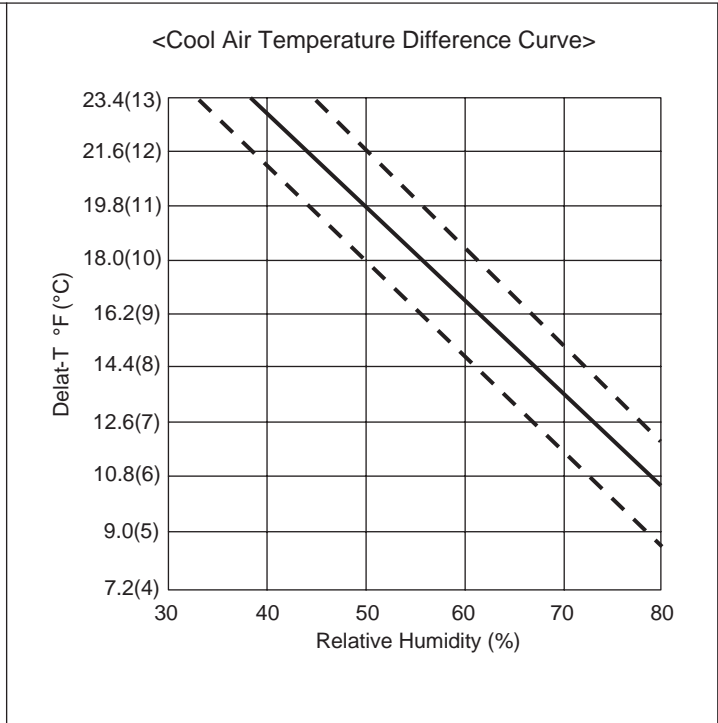
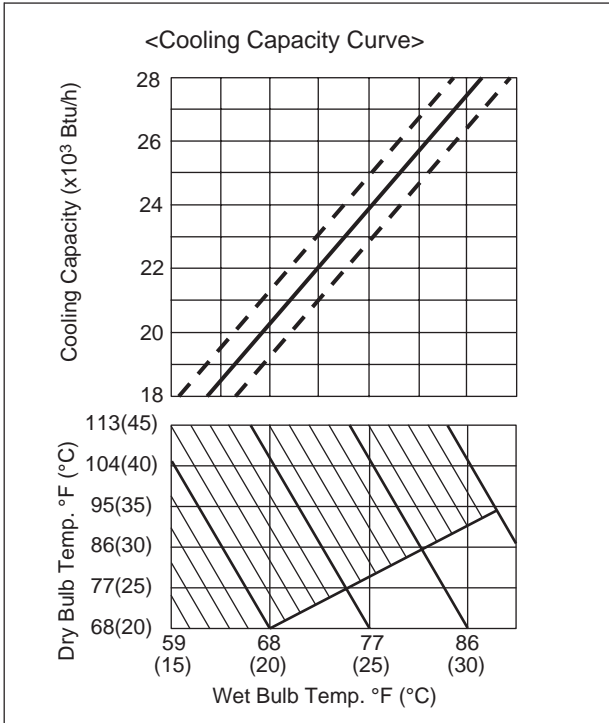

5. REFRIGERANT SYSTEM

5.1 Refrigerant System Construction

The component parts of the refrigerant system include the following:

- Compressor, Evaporator, Condenser, Capillary tube, High Pressure Switch, Modulating Tank

These parts are all connected by copper tubing. All the connections have been brazed.

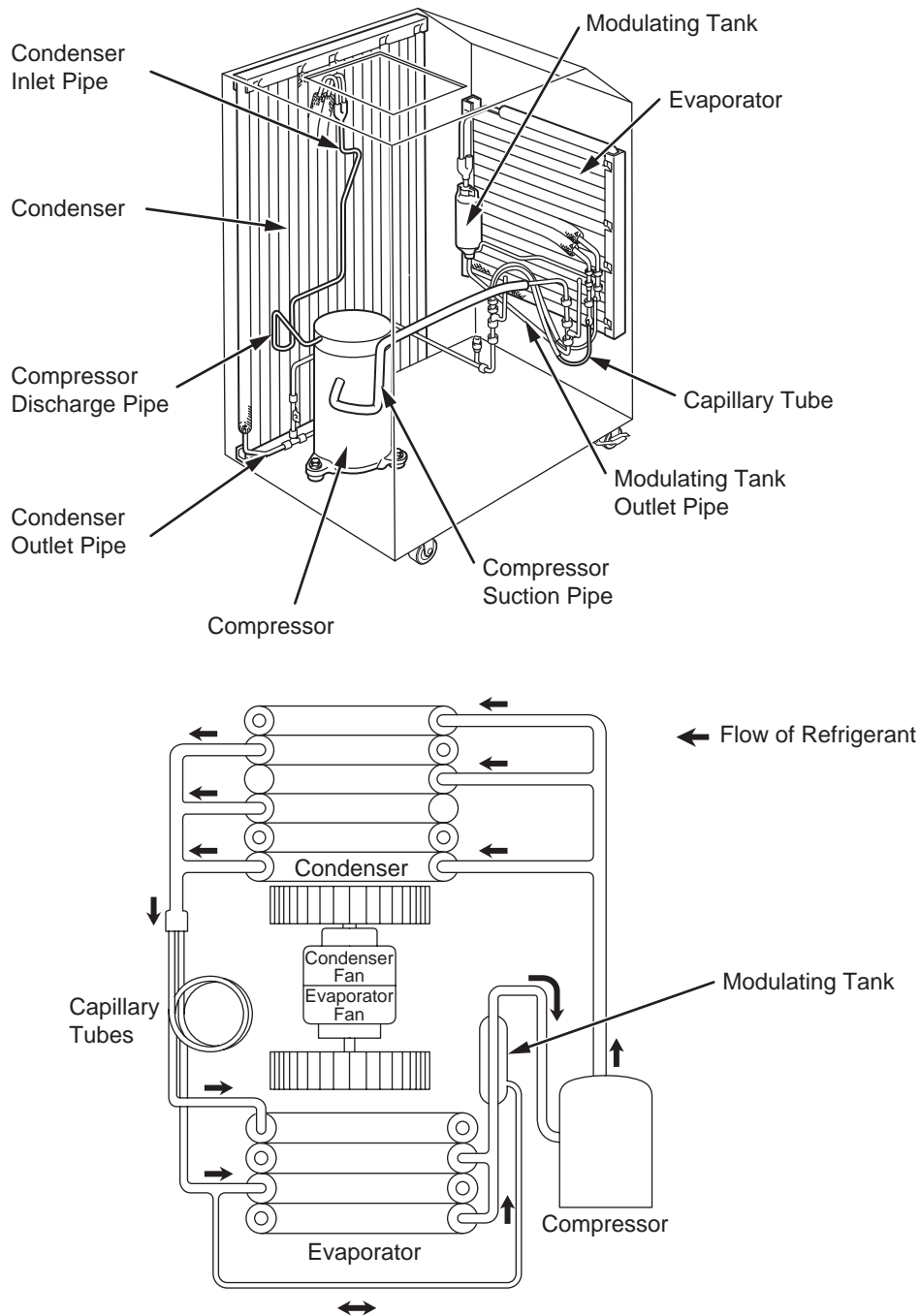

5.2 Compressor

- The compressor used for the unit is hermetically sealed. The compressor and the compressor motor are in one casing.

(1) Compressor theory of operation

- The scroll utilizes an involuted spiral which, when matched with a mating scroll form, generates a series of crescent-shaped gas pockets between the two members. During compression, one scroll remains stationary (fixed scroll) while the other form (orbiting scroll) is allowed to orbit (but not rotate) around the first form. As this motion occurs, the pockets between the two forms are slowly pushed to the center of the two scrolls while simultaneously being reduced in volume. When the pocket reaches the center of the scroll form, the gas, which is now at a high pressure, is discharged out of a port located at the center. During compression, several pockets are being compressed simultaneously, resulting in a very smooth process. Both the suction process (outer portion of the scroll members) and the discharge process (inner portion) are continuous.

(2) Compressor operation

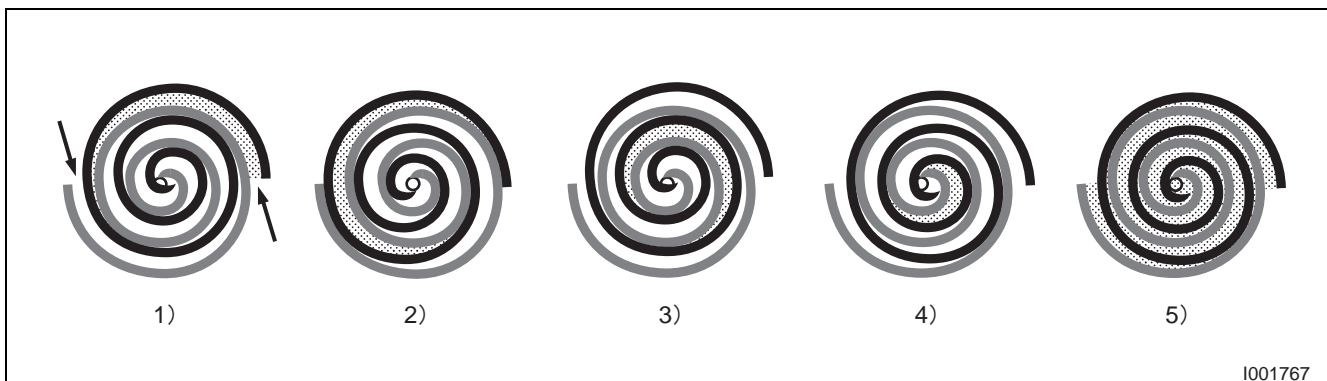

- 1) Compression in the scroll is created by the interaction of an orbiting spiral and a stationary spiral. Gas enters the outer openings as one of the spirals orbits.
- 2) The open passages are sealed off as gas is drawn into the spiral.
- 3) As the spiral continues to orbit, the gas is compressed into two increasingly smaller pockets.
- 4) By the time the gas arrives at the center port, discharge pressure has been reached.
- 5) Actually, during operation, all six gas passages are in various stages of compression at all times, resulting in nearly continuous suction and discharge.

< NOTE >

When the compressor shuts off, the compressor motor may run backward for a moment or two until internal pressures is equalized. This has no effect on compressor durability but may cause an unexpected sound after the compressor is turned off and should not be diagnosed as a malfunction.

5.3 Condenser

- The condenser is a spine fin type heat exchange device consisting of copper tubes passing through an aluminum fin.
- Heat is given off and absorbed by air being pulled across the condenser fins by the centrifugal fan and then expelled through the exhaust air duct.

5.4 Capillary Tube

- The capillary tube is a long thin tube utilizing line flow resistance to serve as an expansion valve. The length and the inner diameter of the capillary tube are determined by the capacity of the refrigeration system, specified operating conditions, and the amount of refrigerant. The capillary tube causes the high pressure, high temperature liquid refrigerant sent from the condenser to expand rapidly as the refrigerant is sprayed out through the fixed orifice in the capillary tube. As a result, the temperature and state of the refrigerant becomes low and mist-like respectively, causing it to evaporate easily.

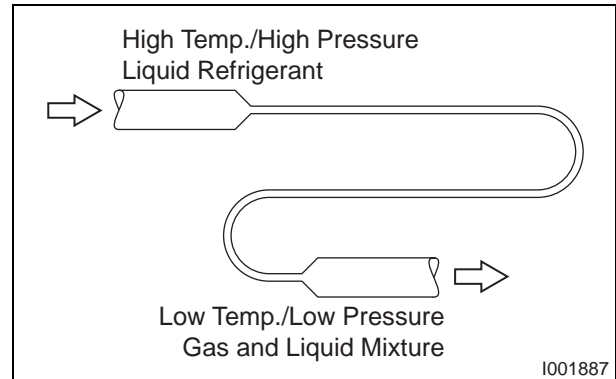

5.5 Evaporator

- The evaporator, like the condenser, is a heat exchanger covered with spine fins. Heat is removed from the air being pulled across the evaporator by the centrifugal fan and the resulting cool air is expelled through the cool air vent.

5.6 High Pressure Switch

- The high pressure switch prevents the condenser and compressor from being damaged by excessively high pressure in the high pressure line of the refrigeration cycle. The switch is normally closed. The snap disk responds to the variations in pressure and, if pressure is abnormally high, the snap disk moves down to push the pin down, causing the internal contacts to open. This interrupts the ground signal at the control board (J104 connector) which turns the compressor off.
- Possible causes of this trouble include:
 - The condenser air filter is dirty, restricting air flow.
 - The condenser blower is defective.

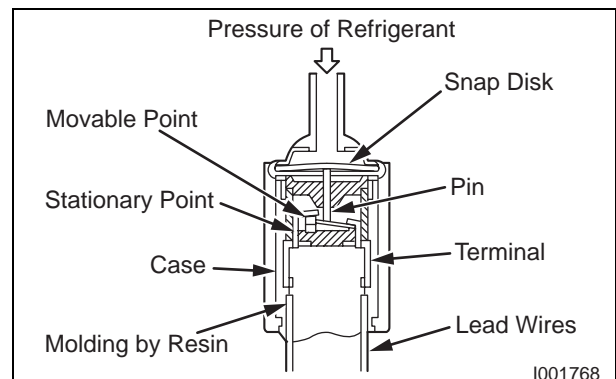

5.7 Modulating Tank

- The modulating tank consists of a copper pipe and tank sections, each being separated from the other. The pipe connects to the evaporator outlet at one end and to the compressor at the other; the tank connects to the evaporator inlet. The modulating tank is covered with insulation to reduce thermal effects of ambient temperature. It varies the quantity of refrigerant in the refrigerating cycle for optimum operating condition; it stores part of refrigerant under light load and delivers additional refrigerant to the cycle under heavy load.

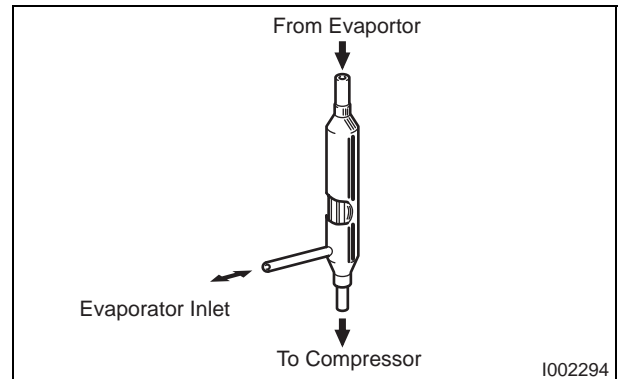

6. ELECTRICAL SYSTEM

6.1 Circuit Diagram and Control Box

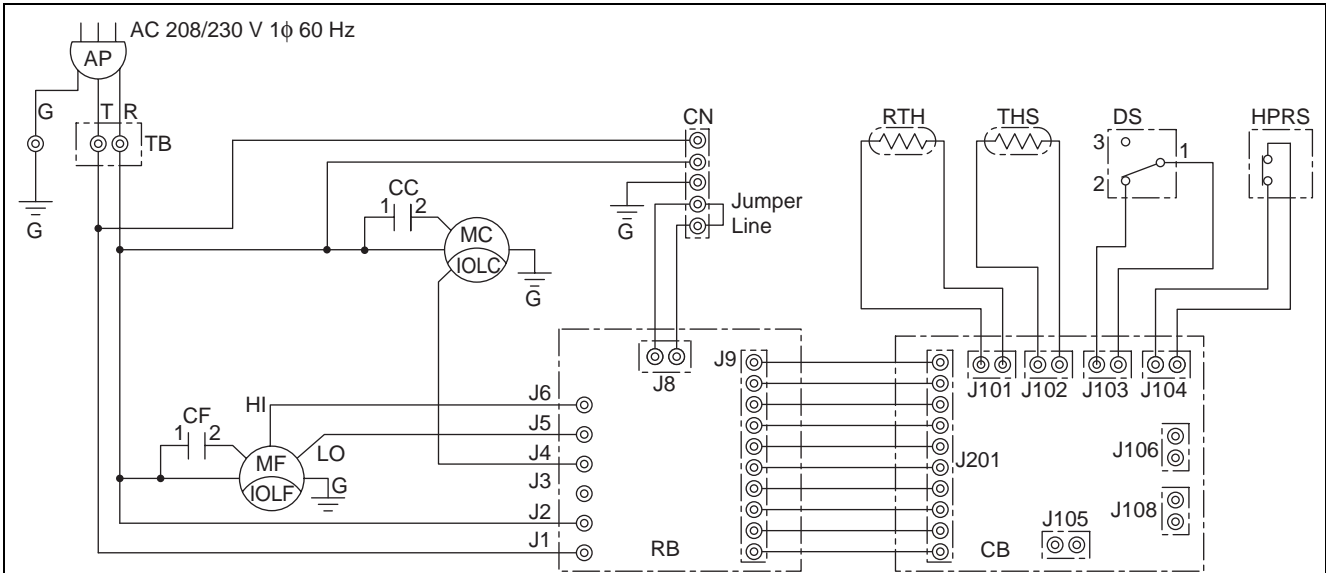

A	P	Attachment Plug
T	B	Terminal Block
C	B	Control Board
R	B	Relay Board
M	F	Fan Motor
M	C	Compressor Motor
C	F	Capacitor for Fan Motor
C	C	Capacitor for Compressor

I O L F	Inner Overload Relay of Fan Motor
I O L C	Inner Overload Relay of Compressor
D S	Full Drain Warning Switch
T H S	Freeze Protection Thermistor
R T H	Room Thermistor
G	Grounding
H P R S	High Pressure Switch
C N	Connector for Option Drain Pump

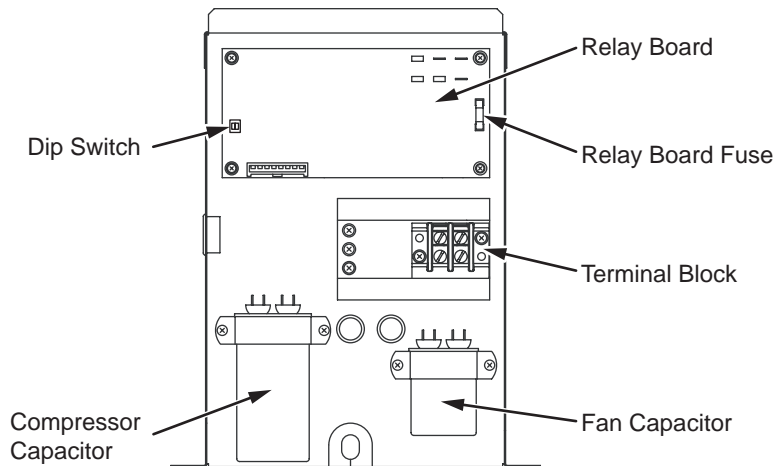

6.2 Basic Operation of The Classic Plus 26 Electrical Circuit

- There are two basic components used to control the operation of the Classic Plus 26 electrical system:
 - Control panel assembly
 - Control box
- The control panel assembly contains the control panel, control board (with inputs for the freeze and room temperature thermistors), drain switch, high pressure switch and a microprocessor.

(1) Fan mode

High Fan Mode

- When the FAN MODE button on the control panel is pressed, the microprocessor turns on “FAN HI” “COOL OFF” indication of LCD and activates both the fan on relay and fan mode relay. This sends line voltage (208/230 VAC) from the fan on relay to the N.O. (normally open) contacts of the fan mode relay. This output is connected to the J6 terminal (relay board) where the high speed wire of the fan motor is connected.
- When this button is pressed again, fan turns to low mode (see below). Press again, fan stops.

Low Fan Mode

- When the FAN MODE button on the control panel is pressed again, the microprocessor turns on “FAN LO” “COOL OFF” indication of LCD and activates both the fan on relay and fan mode relay. This sends line voltage (208/230 VAC) from the fan on relay to the N.C. (normally closed) contacts of the fan mode relay. This output is connected to the J5 terminal (relay board) where the low speed wire of the fan motor is connected.
- When this button is pressed again, fan stops.

(2) Cool mode

- In addition to fan mode (as described above), when the COOL ON/OFF button on the control panel is pressed, the microprocessor turns on “COOL ON” indication of LCD and if the temperature set point is less than the current room temperature, activates the compressor relay (relay board) after 120 sec delay. This sends line voltage (208/230 VAC) to the J4 terminal (relay board) where compressor wire is connected. Then compressor turns on for Cooling Operation.

6.3 Control Box

(1) Capacitors

- The capacitors are used to temporarily boost the power output available to the fan motor and the compressor at start-up.
- The specifications of each capacitor are listed below:

Capacitor Application	Voltage	Rating Capacitance
Fan Motor	440 VAC	12.5 μ F
Compressor	370 VAC	40 μ F

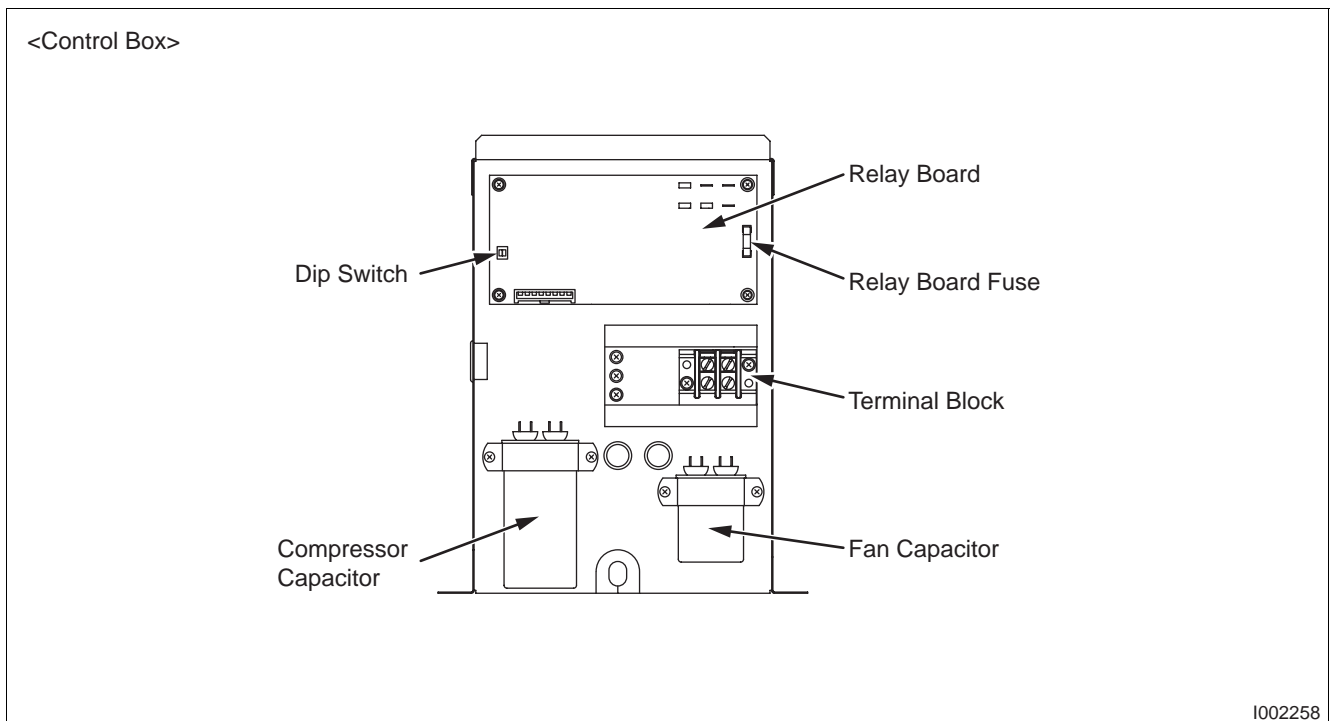

(2) Relay board

- The relay board receives signals and outputs from the control board that contains a microprocessor. The relay board contains the compressor, fan on and fan mode (speed) relays.
- It also contains a step-down transformer that converts the line voltage (208/230 VAC) to 12 V.
- This 12 V is then converted from AC to DC and used for relay coil activation. The 12 V (DC) power is sent to the control panel assembly where it is further reduced to 5 V for the system logic.
- The relay board also contains the DIP switch.
- The DIP switch is used to change the fan mode operation from stop to operate and change both the set point and room temperature display from Fahrenheit to Celsius.

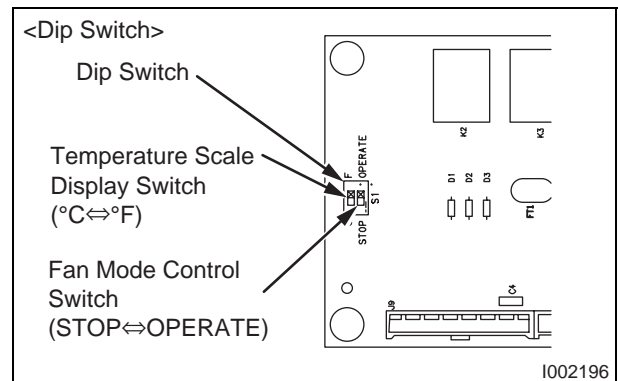

< NOTE >

The relay board must be serviced as a complete assembly. It has only one serviceable component, the fuse. (see below)

(3) Relay board fuse

- This fuse provides protection against damage to the step-down transformer. It must be replaced with the exact type of fuse or an equivalent.

Specifications:

- 0.25 A, 250 V

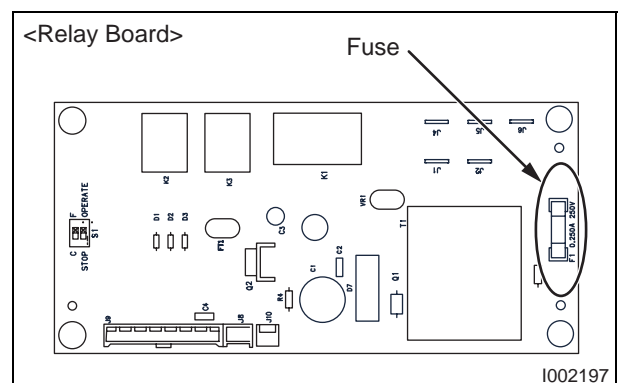

⚠ CAUTION

Failure to use the exact type of fuse could result in damage to the unit and/or to components. It could also void the warranty of the unit.

6.4 Fan Motor

- The fan motor is a single phase, induction type two-speed motor.

The motor rotates the fan on both the evaporator side and the condenser side at the same time.

Specifications:

- Rated Voltage: 230 V, 60 Hz
- Rated Output: High-550 W, Low-380 W

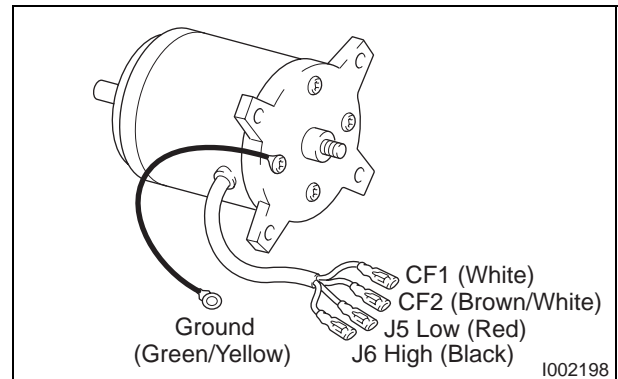
**< NOTE >**

An internal overload relay is used to protect the fan motor. This relay is built into the fan motor and interrupts the flow of current when there is an over current situation, or if abnormally high temperature builds up in the fan motor.

6.5 Compressor Motor

- The compressor motor is a single-phase motor and is contained within the same housing as the compressor.

Specifications:

- Rated Voltage: 208/230 V, 60 Hz
- Rated Output : 1600 W (at 230 V)

< NOTE >

An internal overload relay is used to protect the fan motors and the compressor motor. This relay is built into the fan motors and compressor motor. It interrupts the flow of current when there is an over current situation or if abnormally high temperature builds up in the fan motors and compressor motor.

6.6 Power Cord with LCDI

- Classic Plus 26 is equipped with a UL approved LCDI cord and an approved NEMA plug configuration (6-20). The appropriate outlet must be used for this plug type. LCDI is used for monitoring leakage current. Once leakage current is detected, LCDI de-energizes the unit.

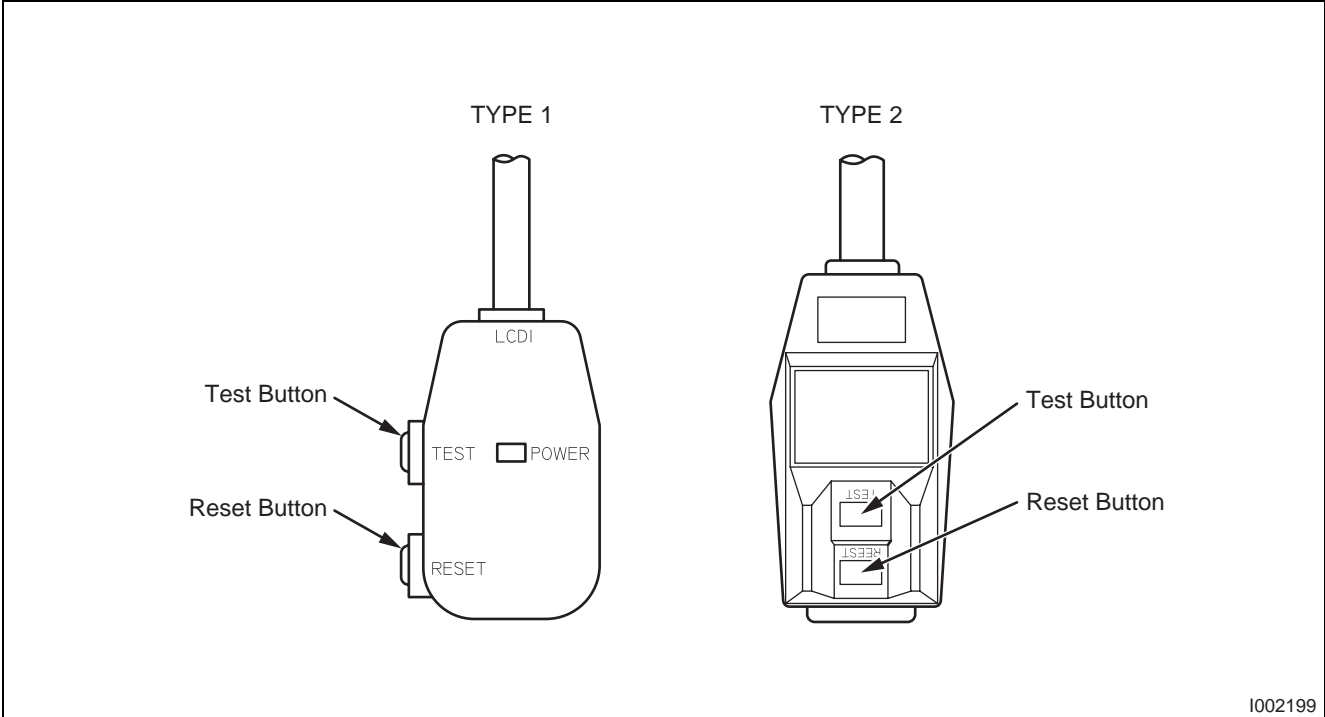

6.7 Drain Switch

- The Classic Plus 26 is equipped with a drain tank switch. When the drain tank accumulates approximately 4.0 gal (15 L) of condensate (water) in the drain tank, the drain tank switch sends a signal to the microprocessor. The microprocessor stops all operation of the unit, flashes the "TANK FULL" LED, indicates "TANK FL" on the LCD and closes the contact of output signal.
- This system utilizes a 0.1 A, 125/250 VAC micro-switch for this function. When drain water accumulates approximately 4.0 gal (15 L) in the drain tank, the drain tank base plate, which is supported at its fulcrum, is pushed down in the arrow direction as shown in the figure below.
- When the drain tank base plate is forced down, the top of the drain tank base plate turns off the contacts #1-#2 of the micro switch. This causes the ground signal at the J103 connector of the control panel assembly to go open. When the microprocessor detects this event, it shuts the unit off, flashes the "TANK FULL" LED, indicates "TANK FL" on the LCD and closes the contact of output signal.
- When the drain tank is removed (or the drain tank is emptied), the top of the drain tank base plate returns to its original position from the tension of the coil spring. Then contacts #1-#2 of the drain tank switch close. This provides a ground to the microprocessor through the J103 connector.

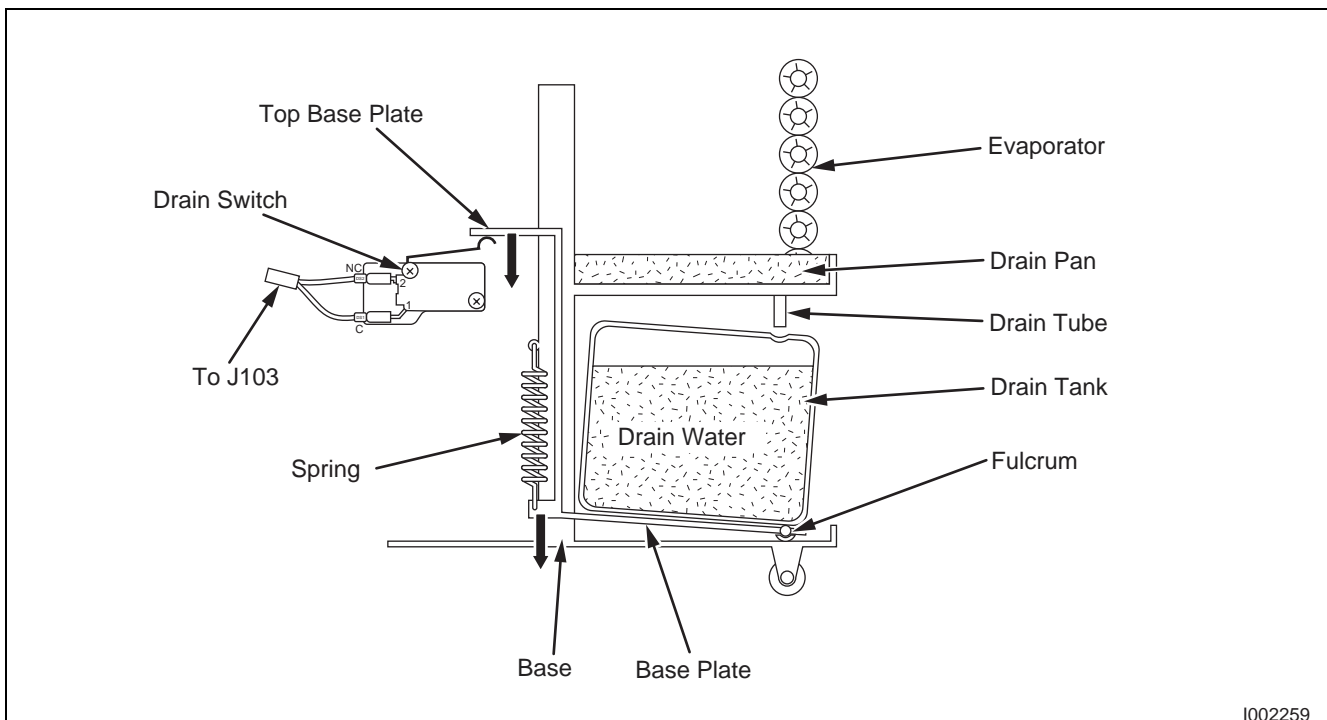

(1) How to re-start the unit

- If the LCD indicates “PROGRAM ON”, press the COOL ON/OFF button to continue running the program. If the LCD indicates “PROGRAM ON” continuously (program activated), no further steps are necessary. If no program exists or the program was deactivated, press the FAN MODE button or the COOL ON/OFF button. The unit returns to the previous temperature set point.

6.8 Condensate Pump Kit (optional)

- The Classic Plus 26 model comes standard with a drain tank, which collect the water that forms on the evaporator during normal cooling operation. If the unit is required to operate continuously without periodic emptying of this tank, a condensate pump may be needed. A condensate pump kit is available for the Classic Plus 26 model.

6.9 Automatic Restart after Power Interruption

- The program within the microprocessor of the Classic Plus 26 contains a feature that automatically restarts the unit after power is lost and then regained. The unit also has memory in order to return itself back to the operating mode (either manual or preset program) it was in prior to the loss of power. All preset programs are retained in the memory in the event power loss occurs.

6.10 Compressor Protection

- There is a time delay program within the microprocessor. This prevents a heavy load from being applied on the compressor motor when restarting the unit cool mode after a very short period of time. This delay is in effect any time when the compressor is turned on by either the COOL ON/OFF button, temperature set point (thermostatic control), power interruption restart or condensate pump (optional) operation.

Specifications:

- Time delay
- 120 ± 20 sec.

6.11 Temperature Control

- The compressor operation cool mode is controlled by the microprocessor which receives input signals from the room temperature thermistor (evaporator inlet air) and the setting of the temperature set point. The temperature set point (desired room temperature) can be adjusted by pressing the Δ/∇ buttons on the control panel. The adjustment range of the temperature set point is 70 °F to 95 °F (21 °C to 35 °C).

6.12 Fan Mode Control Switch

- The fan motor operation is controlled by relays on the relay board through a microprocessor in the control panel assembly. The fan program in the microprocessor can be changed by a DIP switch on the left side of the relay board located in the control box.
- There are two settings:

(1) Cool to stop

- When the DIP switch is set in the downward or STOP position, the microprocessor controls the fan motor using the same room temperature thermistor that it uses to control the compressor. In this case, both the fan and the compressor stop when the microprocessor receives a sufficiently low intake air (room temperature) signal from the thermistor (equal to or less than the set point). When the temperature increases (exceeds the set point) the microprocessor restarts the fan and compressor automatically. However, if the unit has been off for less than 120 sec, the fan starts before the compressor (time delay feature).

(2) Cool to operate

- When the DIP switch is set to the upward or OPERATE position, the microprocessor controls the fan operation using control panel inputs only. The fan operates continuously during fan only and cool modes. (This is the factory default setting.)

6.13 Temperature Scale Display Switch

- When the DIP switch is set in the down or “°C” position, the set point and room temperature are displayed in degrees Celsius. “°C” is indicated on the LCD. When the DIP switch is set in the up or “°F” position, the set point and room temperature are displayed in degrees Fahrenheit . “°F” is indicated on the LCD. (This is the factory default setting.)

7. TROUBLESHOOTING

7.1 Troubleshooting

- Before troubleshooting the system, the following inspection should be performed.

(1) Inspection of power source voltage

- Check the voltage of the power source.
 - Single phase 208/230 V (60 Hz)
- Check the operation and condition of the fuse or circuit breaker in the power source.

(2) Inspection of air filters

- Remove the air filters and check the element. If the element is dirty, wash it as described in the OPERATION MANUAL supplied with the unit.

(3) Inspection of drain tank





- Make sure tank is fully drained.

The following pages (page 30 to 37) are self-diagnostic codes and troubleshooting information. Detailed information is contained in the OPERATION MANUAL supplied with the unit.

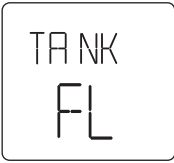
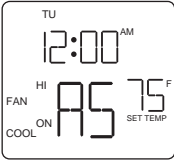
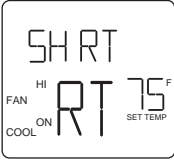
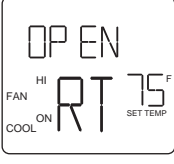
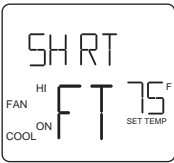
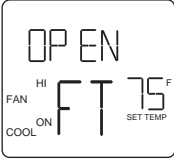
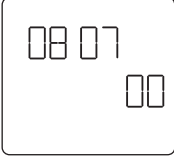
7.2 Self-Diagnostic Codes

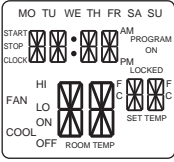
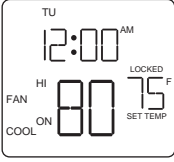
- Self-diagnostic codes are displayed on the control board under the following conditions and clear method is as follows.

LCD Display	Description	Condition	Reset/Remedy
	Drain tank is full	When the drain tank is filled with drain water. (“TANK FL” LED flashes and signal output (J106) turns on.)	1) Drain away. (LCD indicates “TANK”) 2) Press ON/OFF button.
	Condensate pump problem	When (optional) condensate pump is damaged or broken. (J8 input of relay board turns to open and signal output (J106) turns on.)	1) Fix the condensate pump. 2) Reset the system. To RESET: Press ON/OFF and HI/LO buttons on the control box simultaneously for 5 sec.
 	Defect (short or open) of room thermistor	When room thermistor (connecting to J101) becomes short or open. (Signal output (J106) turns on.)	Disconnect and reconnect the room thermistor. If it doesn't work, then change it.
 	Defect (short or open) of freeze protection thermistor	When freeze protection thermistor (connecting to J102) becomes short or open. (Signal output (J106) turns on.)	Disconnect and reconnect the freeze protection thermistor. If it doesn't work, then change it.
	Show running hours	Press ON/OFF and ▽ buttons simultaneously for 3 sec, total operation hours of compressor is indicated by 6-digit (hours). Example in left: 807 h	After 5 sec., display goes back to normal mode.

LCD Display	Description	Condition	Reset/Remedy												
	<p>Show LCD and LED all on mode</p>	<p>Press HI/LO and Δ buttons simultaneously for 3 sec. (To check LCD segments and LED display.)</p>	<p>After 5 sec., display goes back to normal mode.</p>												
	<p>Key lock mode (LCD displays "LOCKED".)</p>	<p>Press ENTER and SET CLOCK buttons simultaneously for 5 sec.</p>	<p>Press ENTER and SET CLOCK buttons simultaneously for 5 sec again to cancel the key lock mode.</p>												
	<p>Indication of model name</p>	<p>Press ENTER and SET CLOCK buttons simultaneously for 5 sec or turn on.</p>	<p>Reset to normal display automatically after 5 sec.</p>												
	<p>Indication of service code</p>	<p>Press ON/OFF and Δ buttons simultaneously for 3 sec. Indication contents is as follows.</p> <table border="1" data-bbox="683 1010 1079 1220"> <thead> <tr> <th>LCD</th> <th>Description</th> <th>Value</th> </tr> </thead> <tbody> <tr> <td>DF</td> <td>Defrost status</td> <td></td> </tr> <tr> <td>FZ</td> <td>Evap. out pipe temperature</td> <td>26\leftrightarrow109F ("26"\leftrightarrow"X9")</td> </tr> <tr> <td>OD</td> <td>Outdoor temperature</td> <td>0 ("00")</td> </tr> </tbody> </table>	LCD	Description	Value	DF	Defrost status		FZ	Evap. out pipe temperature	26 \leftrightarrow 109F ("26" \leftrightarrow "X9")	OD	Outdoor temperature	0 ("00")	<p>1) See page 34 to 36. 2) Press ON /OFF button.</p>
LCD	Description	Value													
DF	Defrost status														
FZ	Evap. out pipe temperature	26 \leftrightarrow 109F ("26" \leftrightarrow "X9")													
OD	Outdoor temperature	0 ("00")													
	<p>Change model setting</p>	<p>For installing new controller PCB, if a different model name appears when the unit is reset or turned on, change model name according to the correct procedure.</p>	<p>1) While pressing Δ and ∇ buttons, plug the power cord. <Condition> LCD indicates current setting model name and buzzer sounds. 2) After setting the model type by pressing Δ and ∇ button, unplug the unit.</p>												

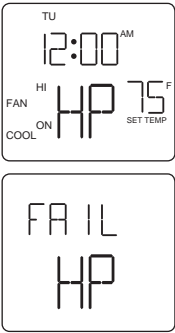
LCD Display	Description	Condition	Reset/Remedy
	Activation of high pressure switch	When high pressure switch (connected to J104) activates (=J104 input turns to open) 3 times in 24 h, "HP" is indicated and signal output (J106) turns on. When it activates 10 times in 24 h, "FAIL HP" is indicated and buzzer sounds.	Find the cause of high pressure to address it. Check the following. Ambient air temperature (77 °F (25 °C), 50 %RH⇔113 °F (45 °C), 50 %RH) Air filter (if dirty, wash up.) Condenser fan motor (if not working, replace.) Defect of high pressure switch (if switch is open when unit is off, replace switch.) Reset the system. To RESET: Press ON/OFF and HI/LO buttons on the control box simultaneously for 5 sec.

7.3 Troubleshooting Chart

- To accurately troubleshoot the problem, it is important to carefully confirm the nature of the problem. Typical problems are:
 - Insufficient cooling.
 - Unit does not start (operate).
 - Overflow of drain water.
 - Abnormal noise or vibrations.
 - Others.

(1) Insufficient cooling

- Cooling system problem generally results from electrical or mechanical components such as fan motor, compressor, control switch.

< NOTE >

- There is a possibility of insufficient cooling due to clogging of the air filter. So make sure to first check if the air filter is clogged or not.
- Check the power supply because of the possibility of power source failure.
- Check the installation site for operating temperature and installation space (unobstructed airflow).

Symptom		Possible Cause		Remedy
		Checking Area	Cause	
Air volume normal	Compressor operates.	1. Usage conditions (high temperature).	Operation near usage limits.	Review the installation place.
		2. Dirt in condenser or evaporator.	Insufficient heat exchange.	Clean fins.
		3. Frost in refrigeration cycle.	Clogging at the frost section.	Replace clogged section.
		4. No temperature difference between evaporator and condenser.	Insufficient refrigerant.	Check the leaking part, then repair and charge refrigerant.
	Compressor does not operate.	1. Compressor coil resistance. (0 ohm or ∞ ohm)	Short or open circuit.	Replace compressor. (In case of short, check the compressor relay.)
		2. Compressor relay on the relay board.	Open circuit or insufficient contact.	Replace relay board.
		3. Capacitor for compressor motor.	Capacitor malfunction.	Replace capacitor.
		4. Voltage.	Low voltage.	Repair power.
Insufficient air volume	No air.	1. Coil resistance of fan motor. (0 ohm or ∞ ohm)	Short or open circuit.	Replace fan motor.
		2. Fan on-off relay on the relay board.	Open circuit or insufficient contact.	Replace relay board.
		3. Fan HI/LO change relay on the relay board.	Open circuit or insufficient contact.	Replace relay board.
	Insufficient air volume.	1. Air filter.	Clogged air filter.	Clean air filter.
		2. Evaporator.	Clogged evaporator or crushed fins.	Repair and clean fins or replace it.
		3. Duct connection state.	Improper connection.	Repair duct connection.
		4. Fan motor.	Insufficient rotation.	Replace motor.

(2) Unit does not start (operate)

< NOTE >

- In this case, there is a possibility of safety device activating due to the clogged air filter. So make sure to first clean the air filter and then start up again to confirm if the problem lies with the air filter.
- Check the installation site for operating temperature and installation space (unobstructed airflow).

Symptom		Possible Cause		Remedy
		Checking Area	Cause	
Does not operate at all	Control Panel display turns off.	1. Voltage.	Power failure.	Repair power.
		2. Ground fault breaker trip.	Ground fault or defective ground fault breaker.	Repair ground fault section. Reset or repair breaker.
		3. LCDI power cord trip.	LCDI power cord trip.	Reset power cord. Replace power cord.
		4. Fuse.	Fuse blown.	Repair shorting section. Replace fuse on the relay board.

Symptom		Possible Cause		Remedy
		Checking Area	Cause	
Control panel display turns on	Control Panel display shows error codes.	1. Display code "FL".	Drain tank (optional) is filled with the drain water.	Discharge the drain water.
			Improper drain switch connection.	Check connection.
			Defective drain switch.	Replace drain switch.
		2. Display code "AS".	Improper routing of drain hose.	Repair drain hose, then reset unit. To RESET: Press ON/OFF and HI/LO buttons on the control box simultaneously for 5 sec.
			Defective condensate pump.	Repair or replace condensate pump, then reset unit. To RESET: Press ON/OFF and HI/LO buttons on the control box simultaneously for 5 sec.
			Missing jumper connector.	Connect jumper connector.
		3. Display code "RT".	Improper room thermistor connection.	Check connection.
			Defective room thermistor (short or open).	Replace room thermistor.
		4. Display code "FT".	Improper freeze protection thermistor connection.	Check connection.
			Defective freeze protection thermistor (short or open).	Replace freeze protection thermistor.
		5. Display code "HP".	Improper high pressure switch connection.	Check connection.
			Defective high pressure switch (short or open).	Replace high pressure switch.
			See "Stops after running a while" of Troubleshooting on page 36.	
		6. Display code "FZ".	See "Stops after running a while" of Troubleshooting on page 36.	

Symptom		Possible Cause		Remedy
		Checking Area	Cause	
Stops immediately after starting	Control panel display normally.	1. Fan on-off relay on the relay board.	Open circuit or insufficient contact.	Replace relay board.
		2. Fan HI/LO change relay on the relay board.	Open circuit or insufficient contact.	Replace relay board.
		3. Fan motor insulation resistance.	Insulation failure on fan motor.	Replace fan motor.
		4. Compressor relay on the relay board.	Open circuit or insufficient contact.	Replace relay board.
		5. Compressor insulation resistance.	Insulation failure on compressor.	Replace compressor.
Stops after running a while	Control panel display normally.	1. Temperature of fan motor (abnormally high).	Operation of safety device (IOLF) due to fan motor malfunction.	Replace fan motor.
		2. Temperature of compressor (abnormally high).	Operation of safety device (IOLC) due to compressor malfunction.	Replace compressor.
		3. Refrigerant leakage.	Insufficient refrigerant or gas leakage.	Repair and charge refrigerant.
		4. Dirt on evaporator or condenser.	Insufficient cooling of evaporator or condenser.	Clean evaporator or condenser.
		5. Duct connection state.	Improper connection.	Repair duct connection.

(3) Overflow of drain water

Symptom		Possible Cause		Remedy
		Checking Area	Cause	
Overflow from the unit.		1. Drain pan.	Cracks in drain pan.	Check and repair.
		2. Water level in drain pan.	Clogged drain hose.	Check and replace.
		3. Drain hole.	Reversed air flow from drain hole.	Insert a trap on discharge drain hose.
		4. Clogged air filter.	Reversed air flow from drain hole due to the excessive negative pressure inside of the unit.	Clean air filter.

(4) Abnormal noise or vibration

- To prevent abnormal noise or vibration, carefully determine the source of the problem and come up with proper countermeasures to solve the problem so that it does not occur again.

Symptom	Possible Cause		Remedy
	Checking Area	Cause	
Abnormal noise or vibration.	1. Fan.	Fan interference.	Repair interfering section.
		Fan deformation.	Replace fan.
	2. Compressor fixing nuts.	Looseness of nuts.	Tighten nuts further.
	3. Piping.	Pipe interference.	Repair interfering section.
	4. Panel fixing screws.	Looseness of screws.	Tighten screws further.

7.4 Basic Inspection

- Perform the following inspection before disassembly.

(1) Inspection of spine fins

- Remove the air filters and inspect the spine fins for any dirt, dust, lint, or debris that may cause poor cooling performance. If spine fin cleaning is necessary, it is recommended that this service be performed by a qualified service technician.

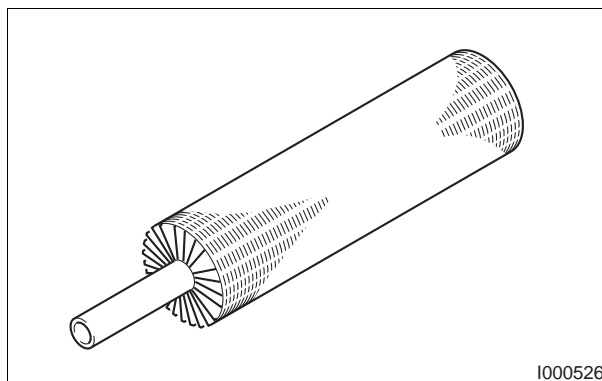

(2) Examination of operating environment

- Operating environments can vary depending on location, climate and surrounding conditions. Installation location also can cause operational problems. Consult your reseller concerning operational environment requirements.

(3) Inspection of cooling capacity performance

- Measure the difference in temperature between the inlet of the evaporator and the cool air vent. If the difference is out of the range given in the graphs on page 14 and 15, proceed with the remedy suggested in the troubleshooting chart on page 32 to 37.

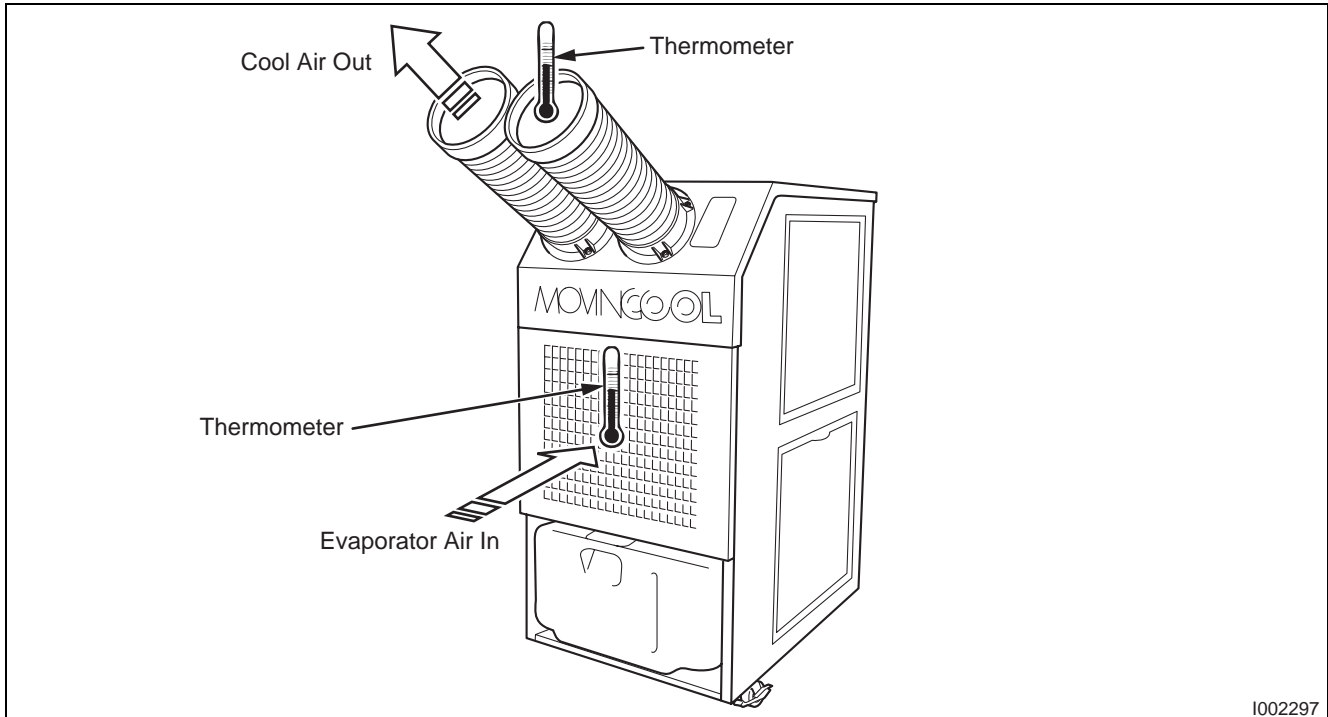

8. DISASSEMBLY

8.1 Parts Construction

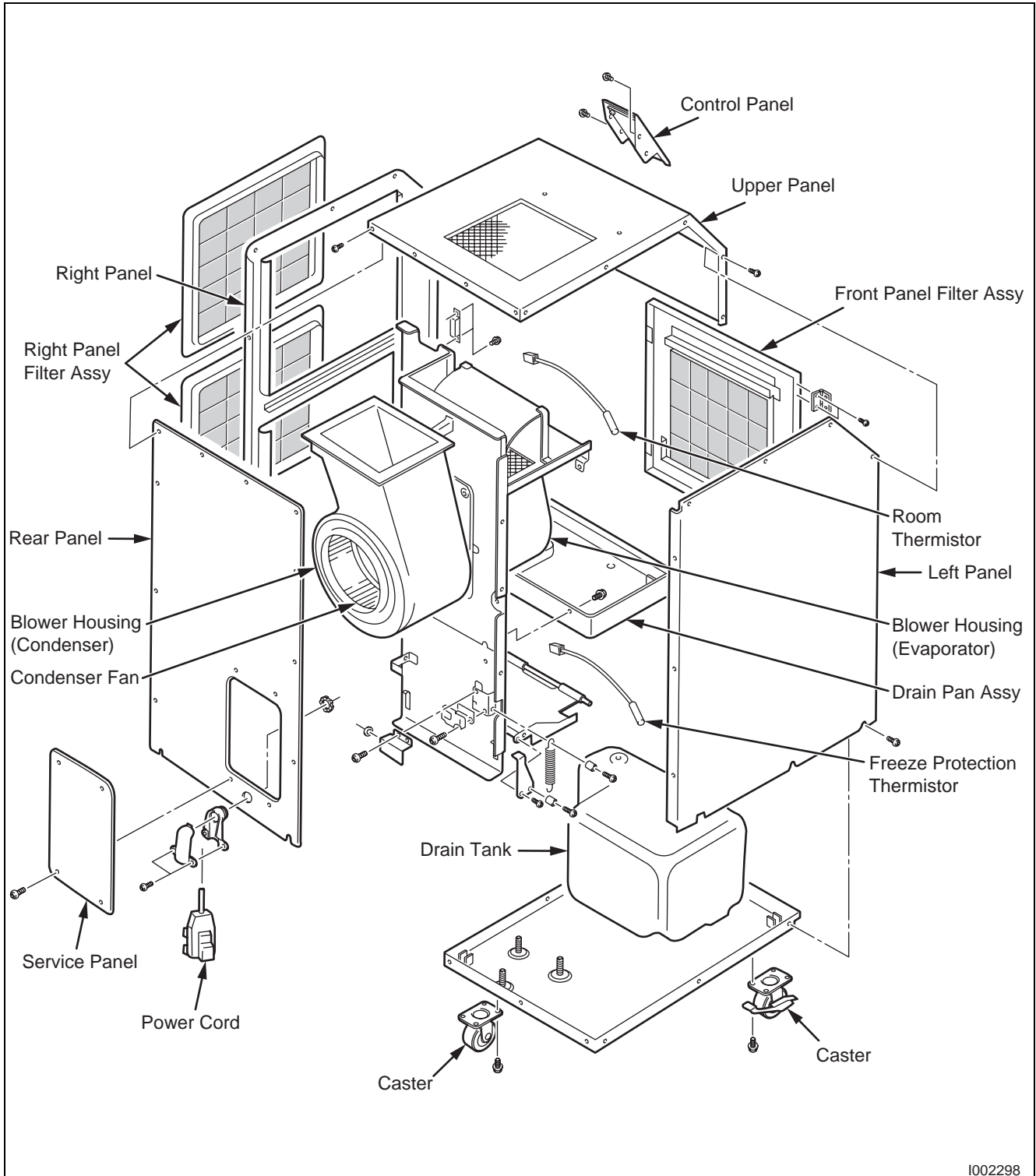

8.2 Disassembly

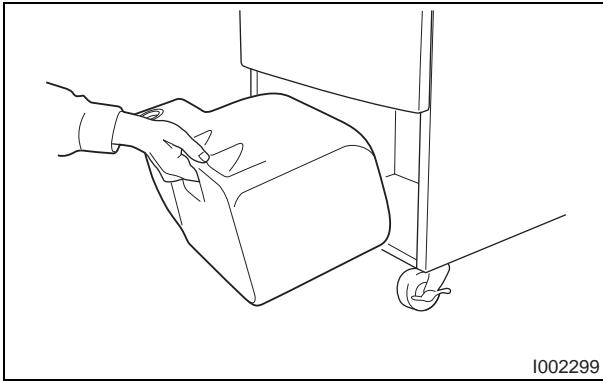

1) Remove drain tank.

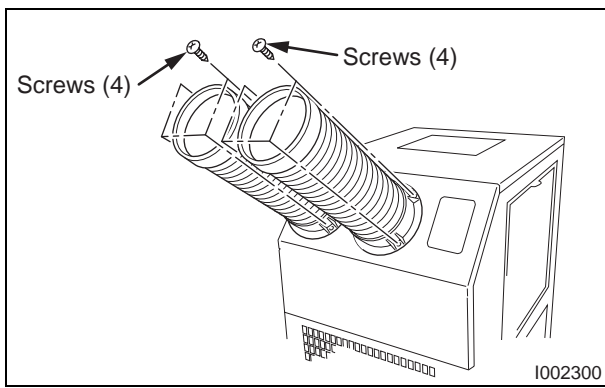

2) Remove eight (8) screws from ducts. Then remove two (2) ducts.

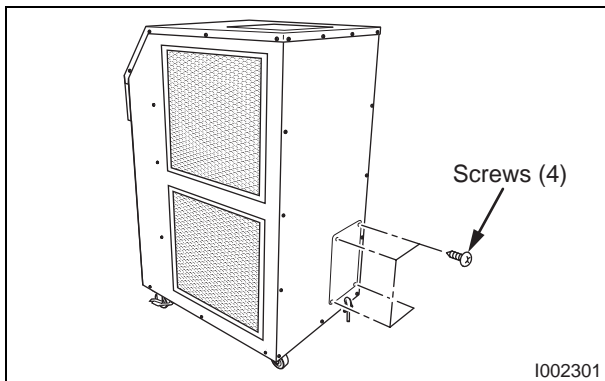

3) Remove four (4) screws from service panel.

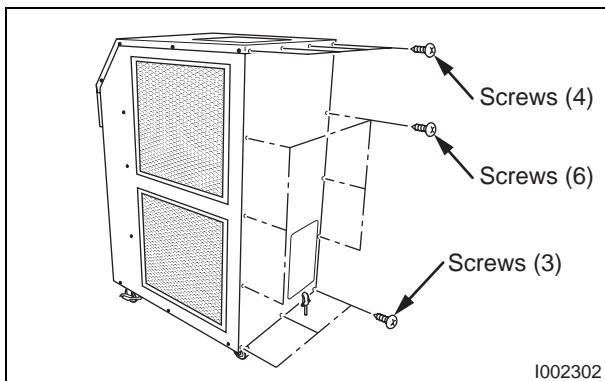

4) Remove thirteen (13) screws from rear panel.

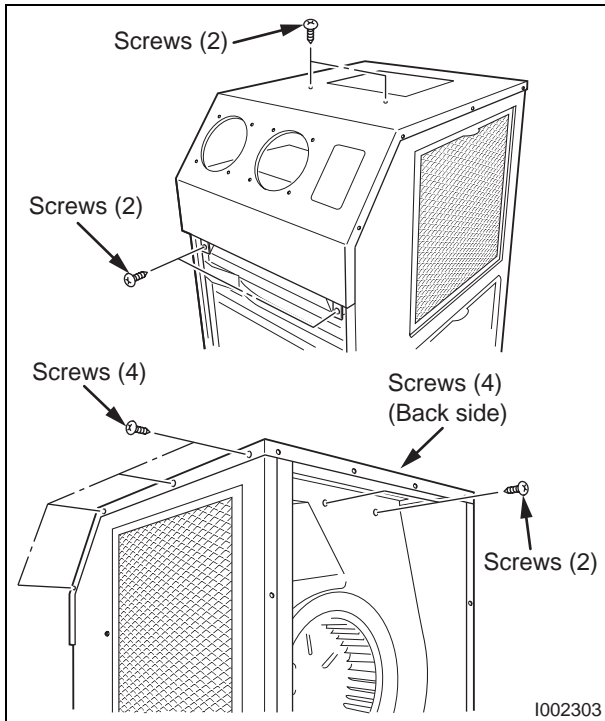

- 5)** Remove twelve (12) screws from upper panel and two (2) screws from blower housing (condenser).

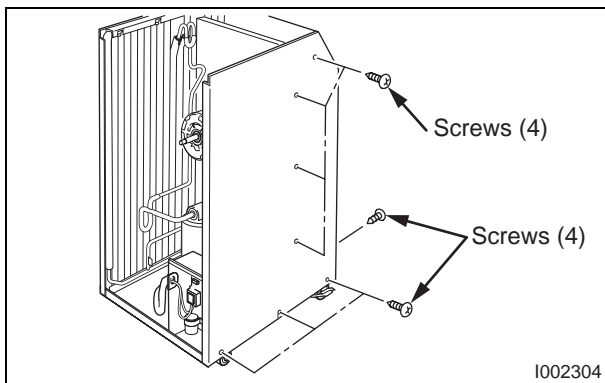

- 6)** Remove eight (8) screws from left panel.

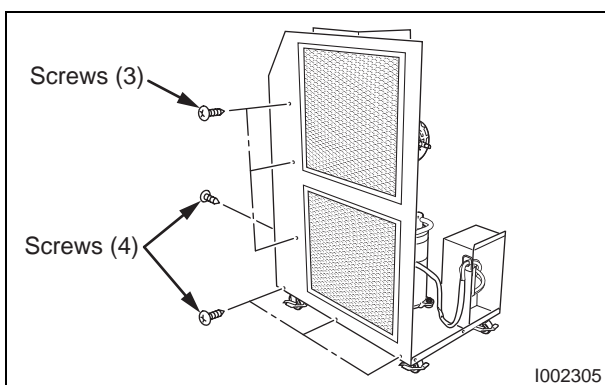

- 7)** Remove seven (7) screws from right panel.

8.3 Removal of Electrical Parts

(1) Control box

- 1) Remove four (4) screws from service panel. (See page 40.)
- 2) Remove electrical parts.
 - Terminal block: Remove two (2) screws from control box.
 - Capacitor: Remove two (2) screws from control box.

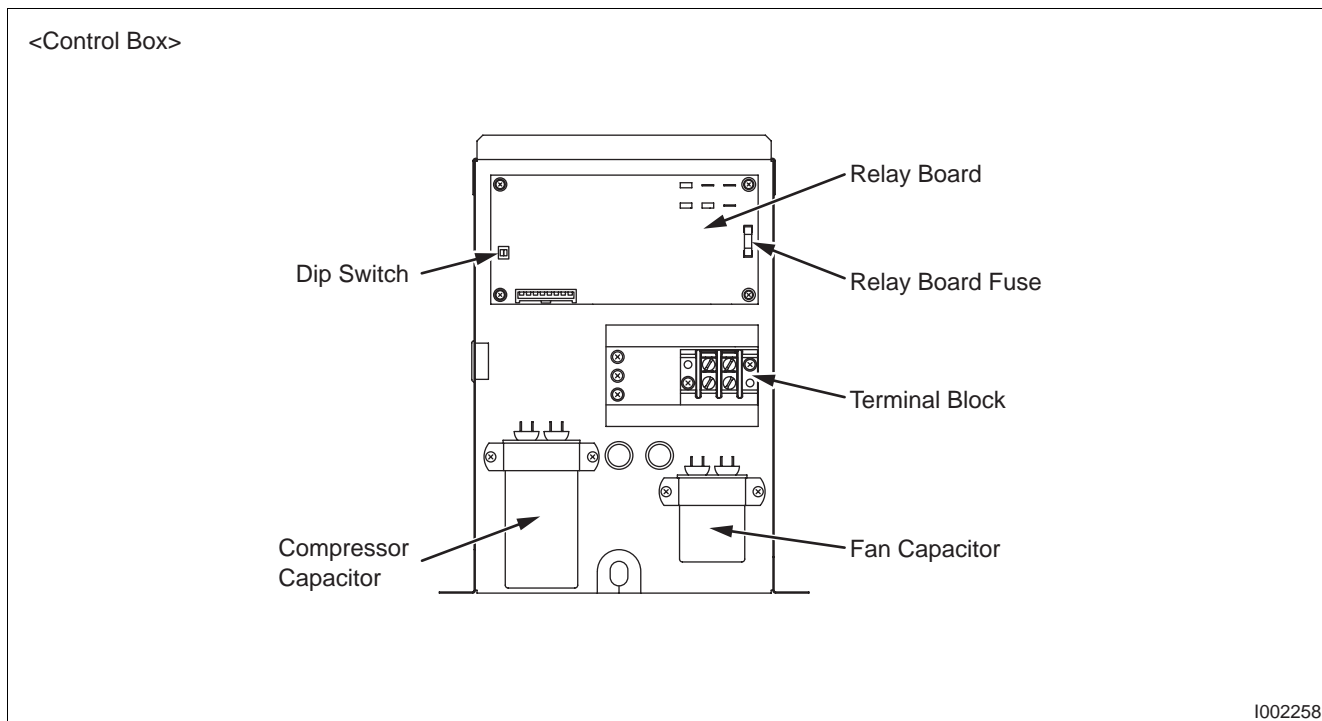

(2) Relay board

- 1) Remove four (4) screws from service panel. (See page 40.)
- 2) Disconnect seven (7) connectors, and remove five (5) screws from relay board.

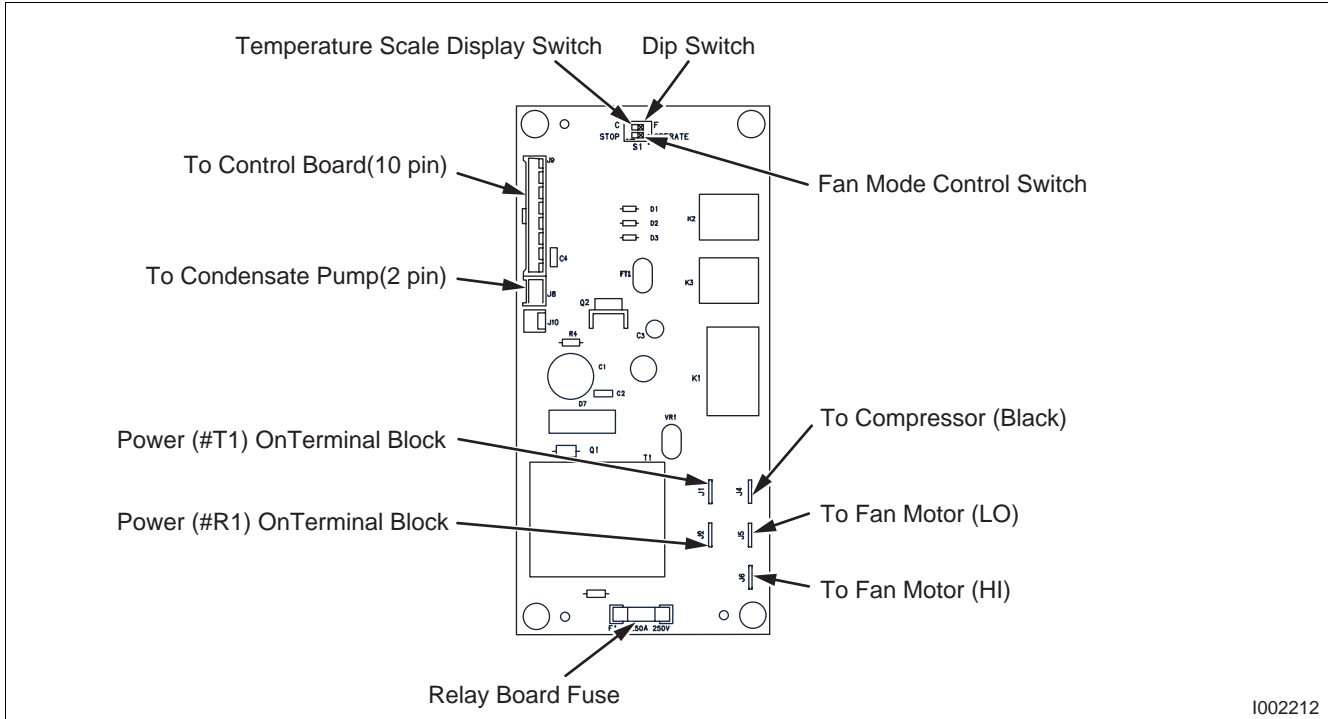

(3) Control board

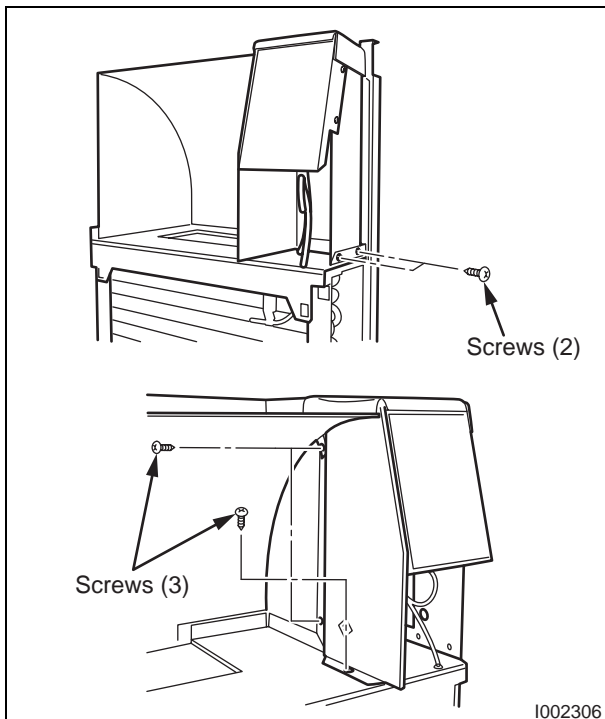

- 1) Remove five (5) screws from the control panel stay.

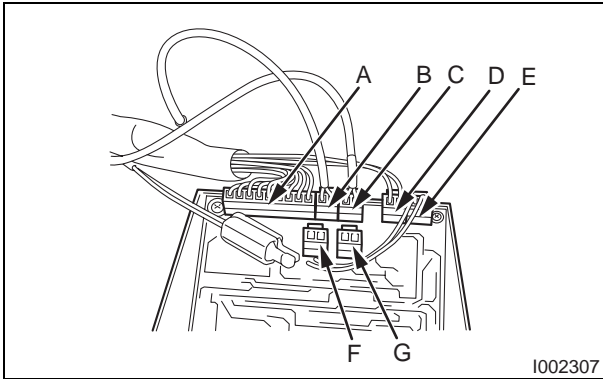

2) Disconnect the following connectors from the control board:

- (A) J201 (10-pin) Wire Harness, Relay Board to Control
- (B) J101 (2-pin) Room Temperature Thermistor
- (C) J102 (2-pin with black tape) Freeze Protection Thermistor
- (D) J103 (2-pin) Drain Tank Switch
- (E) J104 (2-pin) High Pressure Switch
- (F) J106 (2-pin) Not in use.
- (G) J108 (2-pin) Not in use.

< NOTE >

Mark each of the 2-pin connectors with a different color marker to ensure the correct orientation when they are reconnected or label all wire sets with tape. Numbering the wire sets from (A) through (G).

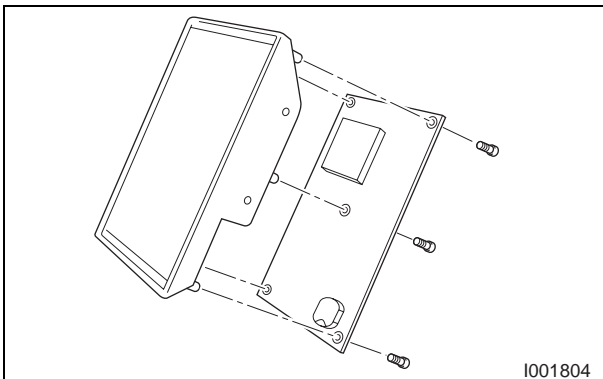

3) Remove the five (5) screws from the control board on the control panel assembly. Remove the control board.

(4) Battery replacement of control board

- When the power is unplugged from the unit, and control board is automatically resetting clock and program, it is time to change the battery on the control board to avoid resetting of clock and program.

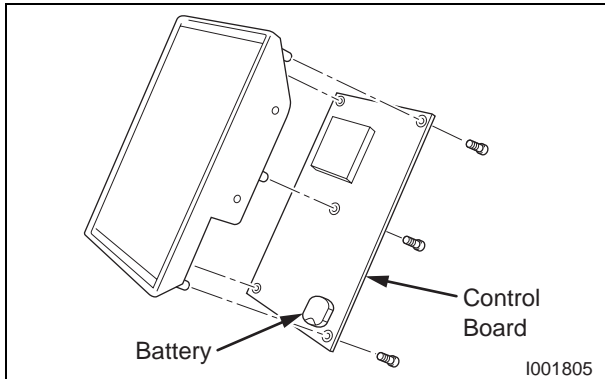

- 1) Disassemble control board. (See page 43 and 44.)

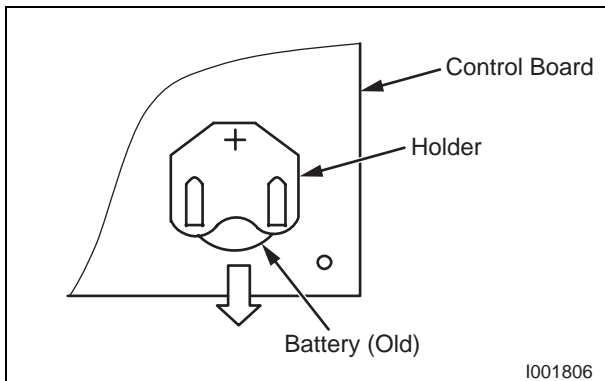

- 2) See diagram for battery removal.

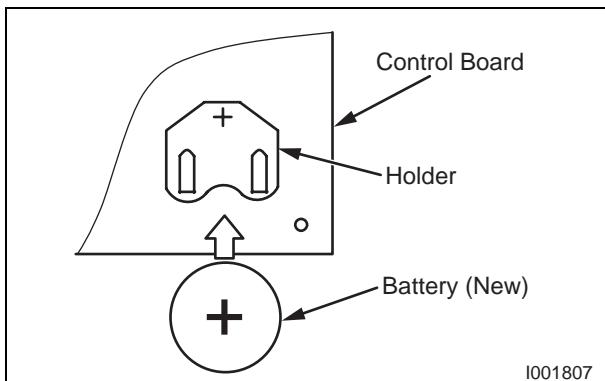

- 3) Insert new battery securely in the direction shown in the drawing.

Specifications:

- Type: 3 V CR2450 or equivalent

CAUTION

When inserting the battery, make sure the direction of polarity (plus/minus) is correct (as shown).

8.4 Removal of Blower Assembly

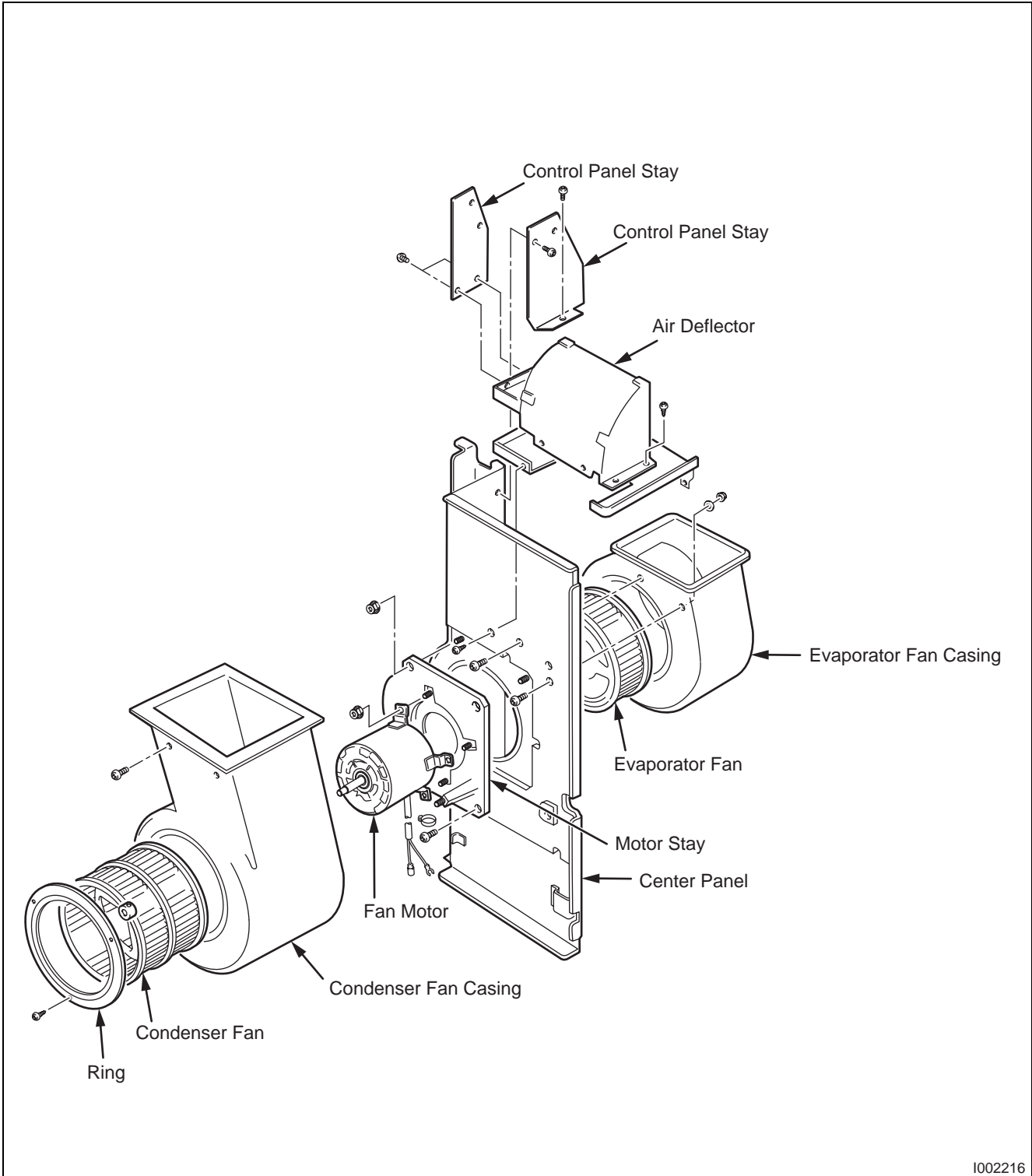

(1) Removal of condenser fan

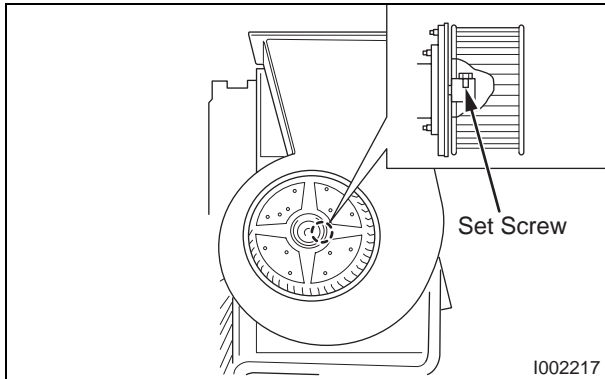

- 1) Loosen the set screw using a hex key. Then remove condenser fan.

(2) Removal of evaporator fan and fan motor

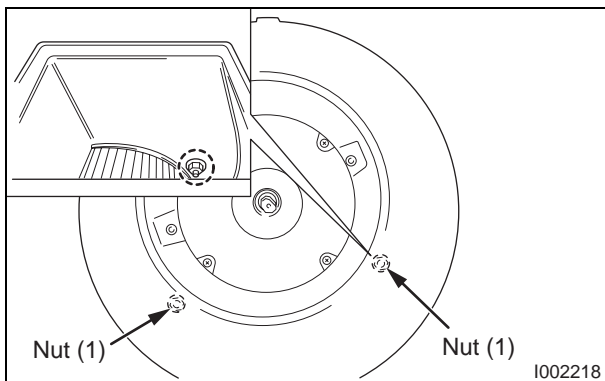

- 1) Remove two (2) nuts on the inside of the condenser fan casing in the locations shown. Then remove condenser fan casing.

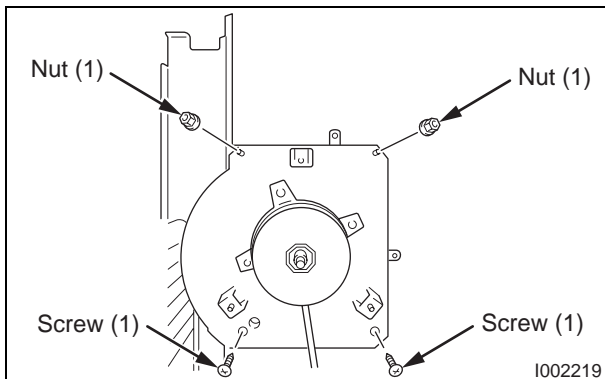

- 2) Remove two (2) nuts and two (2) screws as shown. Then remove the motor stay together with the fan motor.

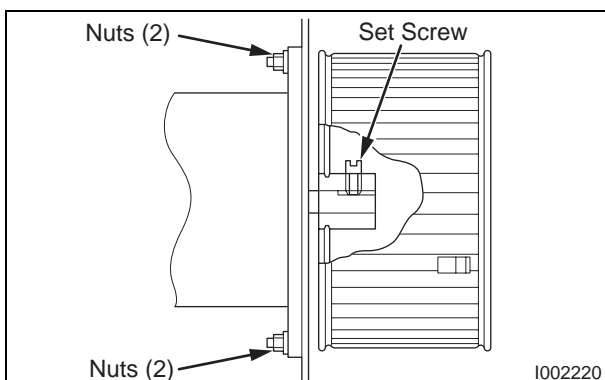

- 3) Loosen the set screw using a hex key. Then remove the fan motor by loosening four (4) nuts.

8.5 Inspection of Capacitor (for Fan Motor and Compressor)

(1) Ohmmeter method

- Set the ohm-meter to the 10M range. Place the two probes against the two terminals of the capacitor. At first, the ohm-meter should indicate small value, then the reading should gradually increase towards infinity. This indicates that the capacitor is charging. If the reading indicates infinity right away (open) or the ohm-meter fails to move from 0. (shorted), replace the capacitor.

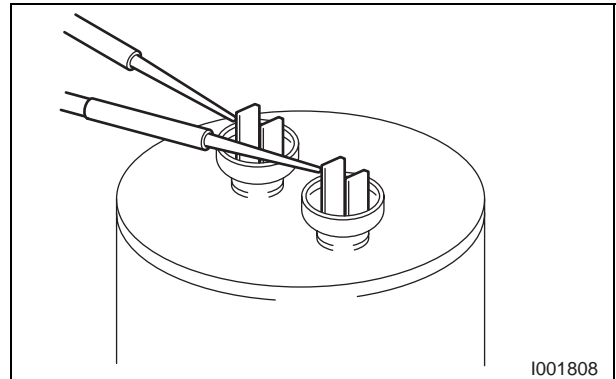

(2) Capacitance tester method

- Using a capacitance tester and the chart on page 22, test the capacitor for the value indicated. If the value tested is not within 10 % of indicated capacitance, replace the capacitor.

⚠ WARNING

- **Properly discharge the capacitor(s) before testing and after testing has been completed.**
- **Failure to do so could cause damage to test equipment or the unit and/or result in personal injury (electrical shock) or death.**

8.6 Inspection of Drain Switch

- Check for continuity between terminals 1 and 2 when drain switch is pressed. With drain switch depressed, there is no continuity between terminals 1 and 2. Replace drain switch if continuity does not satisfy the above condition.

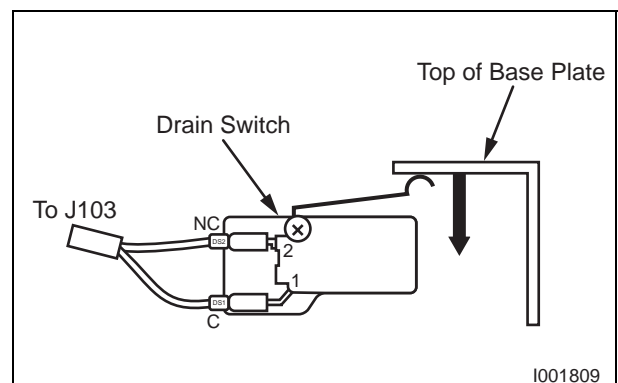

8.7 Inspection of Fan Motor

- Measure resistance across the terminals of the fan motor. (All terminals must be disconnected from the unit.)
- Between terminals (at 77 °F (25 °C))
 - J6-CF1 Approx. 6.8 ohm
 - J6-CF2 Approx. 10.5 ohm
 - CF1-CF2 Approx. 19.0 ohm
- If the measured resistance is not equal to these standard values, replace the fan motor.

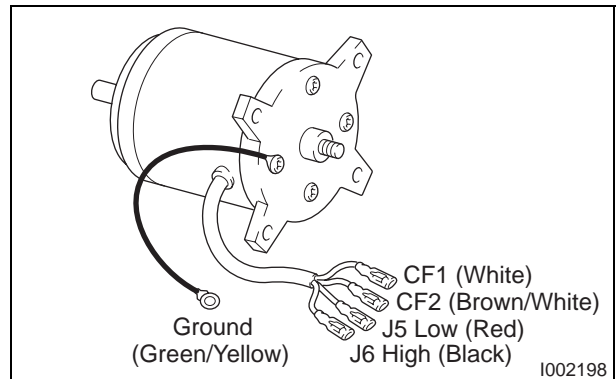

8.8 Inspection of Compressor Motor

- Measure resistance across the terminals of the compressor motor. (All terminals must be disconnected from the unit.)
- Between terminals (at 77 °F (25 °C))
 - R-C Approx. 0.9 ohm
 - C-S Approx. 2.0 ohm
 - S-R Approx. 2.9 ohm
- If the measured resistance is not equal to these standard values, replace the compressor. The overload relay is internal to the compressor.

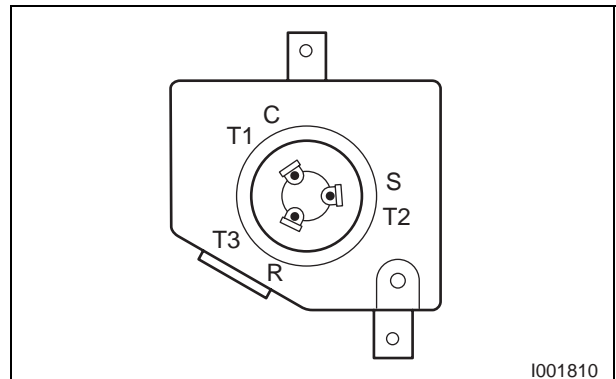

8.9 Inspection of Wiring Connection

- Refer to the Wiring Diagrams on page 20 and check for connection of each wire.

8.10 Inspection of Thermistor

- Using an Ohm-meter, check the resistance value across the 2-pin connector. At normal temperature (77 °F (25 °C)) either thermistor (room or freeze) should measure approximately 10k ohm.

8.11 Inspection

- In most cases, the probable cause for insufficient cooling is a clogged system, leakage or an incorrect amount of refrigerant. In such cases, inspect the system according to the following procedure.

(1) Inspection of clogged system

- Check the component parts of the refrigerant system, including piping, that could be clogged with refrigerant. If clogged with refrigerant, only the clogged part is frosted partially. In such a case, change the part in question.

(2) Inspection of refrigerant leak

- Carefully check all connections, and each component for leaks whenever the refrigerant system is installed or repaired. Use an electronic gas leak tester to inspect the system.

(3) Insufficient refrigerant

- In case the unit is judged to be deficient in cooling capacity, make to perform the inspections in page 51. 9.1 (1) and page 51. 9.1 (2) to confirm the cause of trouble. Then, charge the system with refrigerant to the specified amount.

9. REFRIGERANT SYSTEM REPAIR

9.1 Repair of Refrigerant System

- In case there is a leak, obstruction, or trouble in the refrigerant system of the Classic Plus 26, replace or repair the part in question. After replacing any component all connections must be brazed.

(1) Proper brazing techniques

- It is desirable to use a slightly reducing flame. Oxyacetylene is commonly used since it is easy to judge and adjust the condition of the flame. Unlike gas welding, a secondary flame is used for brazing. It is necessary to preheat the base metal properly depending on the shape, size or thermal conductivity of the brazed fitting.
- The most important point in flame brazing is to bring the whole brazed fitting to a proper brazing temperature. Care should be taken to not cause overflow of brazing filler metal, oxidization of brazing filler metal, or deterioration due to the overheating of flux.

(2) Brazed fittings and fitting clearance

- In general, the strength of brazing filler metal is lower than that of the base metal. So, the shape and clearance of the brazed fitting are quite important. As for the shape of the brazed fitting, it is necessary to maximize its adhesive area. The clearance of the brazed fitting must be minimized to facilitate brazing filler metal to flow into it by capillary action.

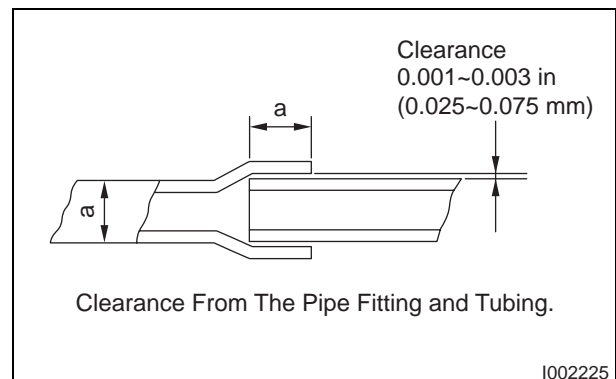

(3) Cleaning brazing filler metal and pipe

- When the refrigerant system has been opened up, exposure to heat may have caused brazing filler metal to stick to the inside and outside of the pipe. Brazing filler metal may also be compounded with oxygen in the air to form oxide film. Fats and oils may stick to the pipe from handling. All these factors can reduce effectiveness of brazing. It is necessary to eliminate excess brazing filler metal using sand paper and by cleaning thoroughly with a solvent such as trichlene.

CAUTION

Do not use chlorine cleaner.

(4) Use of dry nitrogen gas

- During brazing, the inside of the pipe undergoes an oxidative reaction due to the brazing flame. Introduce dry nitrogen gas (0.27 gal/min (1 L/min); adjust with the flow regulator) through the pinch-off tube of the refrigerant.

< NOTE >

Take care not to allow dirt, water, oil, etc. to enter into the pipe.

(5) Vertical Joint

- Heat the whole brazed fitting to a proper brazing temperature. Bring the brazing filler metal into contact with the fitting so that the brazing filler metal starts flowing by itself.
- Stop heating the fitting as soon as the brazing filler metal has flown into the clearance. Since the brazing filler metal flows easily into the portion heated to a proper temperature, it is essential to keep the whole fitting at a proper brazing temperature.

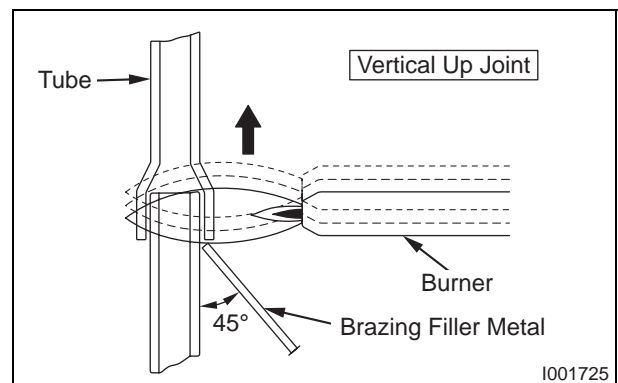
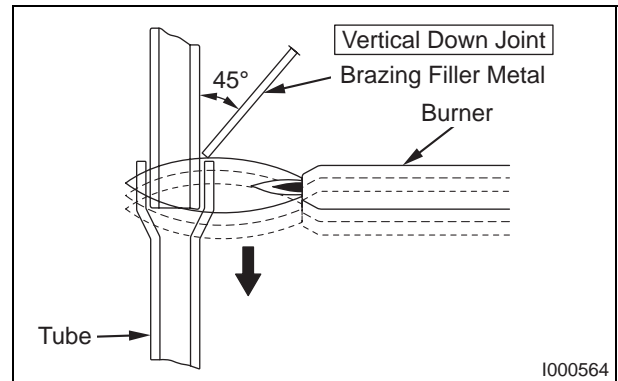

9.2 Removal of Refrigeration Cycle Components

⚠ CAUTION

- Before any refrigeration cycle component can be replaced, it is necessary to recover the refrigerant using standard recovery procedures and equipment.
- To prevent oxidation, dry nitrogen should be conducted (flow rate 0.27 gal/min (1 L/min)) through the pinch-off tube during any brazing operation.
- During any component replacement involving brazing, shield nearby parts with a steel plate, etc., to protect them from the flame.

- Evaporator
- Capillary tube
- Condenser
- Compressor
- High Pressure Switch

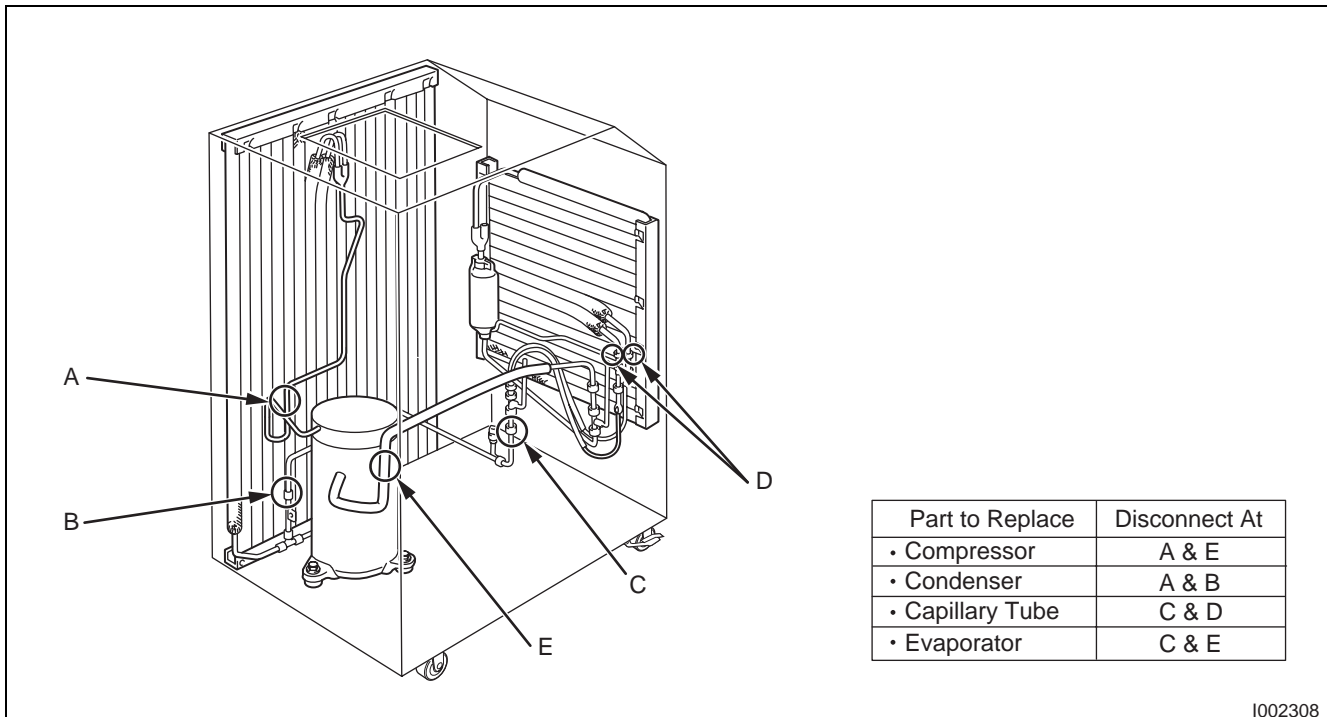

1002308

9.3 Charging the System with R-22 Refrigerant

- Always ensure that the refrigerant system has been properly evacuated before charging with the specified amount of R-22.
- Equipments is only for R-22.

⚠ WARNING

- **When handling refrigerant (R-22), the following precautions should always be observed:**
 - Always wear proper eye protection while handling refrigerant.
 - Maintain the temperature of the refrigerant container below 104 °F (40 °C).
 - Perform repairs in a properly ventilated area. (Never in an enclosed environment.)
 - Do not expose refrigerant to an open flame.
 - Never smoke while performing repairs, especially when handling refrigerant.
 - Be careful the liquid refrigerant does not come in contact with the skin.
- **If liquid refrigerant strikes eye or skin:**
 - Do not rub the eye or the skin.
 - Splash large quantities of cool water on the eye or the skin.
 - Apply clean petroleum jelly to the skin.
 - Go immediately to a physician or to a hospital for professional treatment.

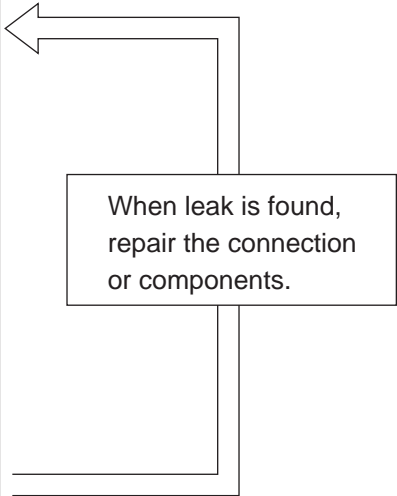
Step 1	Connect manifold gauge.	
Step 2	1) Evacuate the system. <ul style="list-style-type: none"> • 15 min or more. • 30 inHg (100 kPa) or more of vacuum. 2) Stop evacuating the system. <ul style="list-style-type: none"> • Leave for 5 min. 3) Check the vacuum.	
Step 3	Connect to refrigerant source.	
Step 4	Test the system for leaks.	
Step 5	Charge the system with R-22. <ul style="list-style-type: none"> • See specifications on page 12. 	
Step 6	Remove manifold gauge.	

(1) Connection of gauge manifold

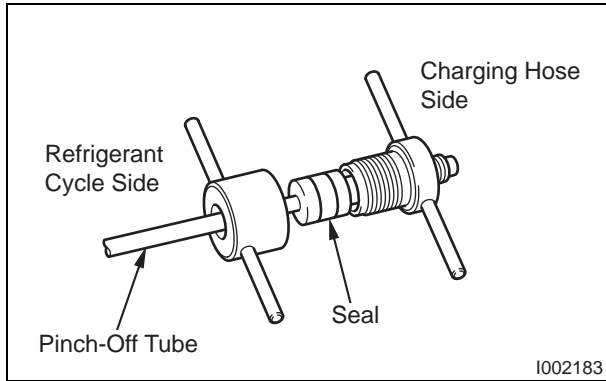

- 1) Properly remove the crushed end of the pinch-off tube at the high pressure side and the low pressure side of the refrigerant cycle with a pipe cutter.
- 2) Fit the process tube fitting to the pinch-off tube on both sides.

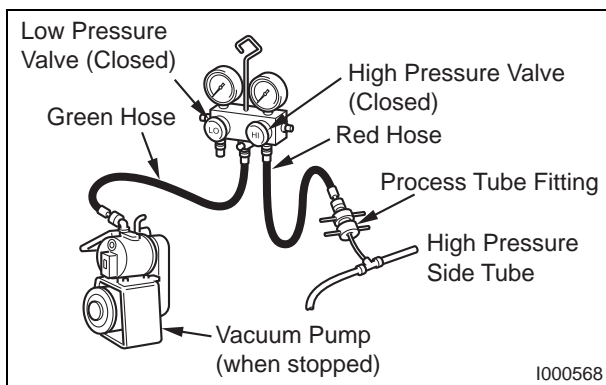

- 3) Connect the charging hoses (red-high pressure side) for the gauge manifold to the process tube fitting.

< NOTE >

Connect the hoses using care not to mistake the high pressure side for the low pressure side and vice versa.

- 4) Connect the charging hose (green) at the center of the gauge manifold to the vacuum pump.

(2) Evacuation

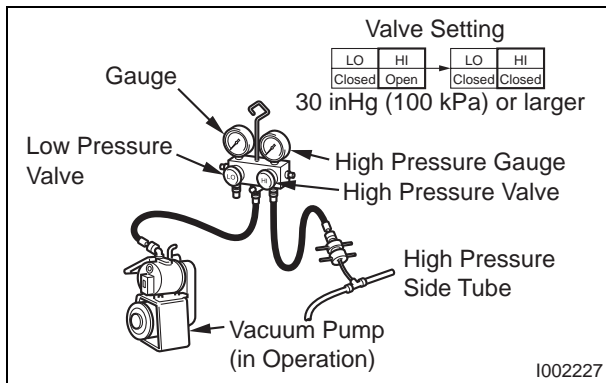

- 1) Open the high pressure valve (HI) of the gauge manifold.
- 2) Turn on the vacuum pump to start evacuation. (Evacuate the system for approximately 15 min.)
- 3) When the low pressure gauge indicates 30 inHg (100 kPa) or larger, turn off the vacuum pump and close the high pressure valves of the gauge manifold.

(3) Checking vacuum

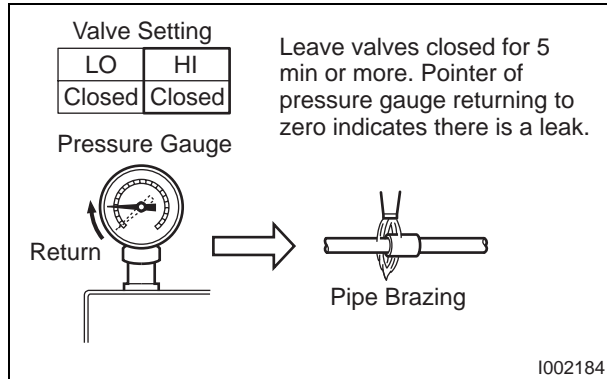

- 1) Leave the high pressure valve and the low pressure valve of the gauge manifold closed for five min or more, and confirm that the gauge pointer does not return to zero.
- 2) If the gauge pointer returns gradually to zero there is a leak somewhere in the system (this could also include gauge manifold). Perform leak check according to procedure indicated in the next step. Once leak has been found and repaired evacuate the system once more, and confirm system holds vacuum.

(4) Checking gas leak

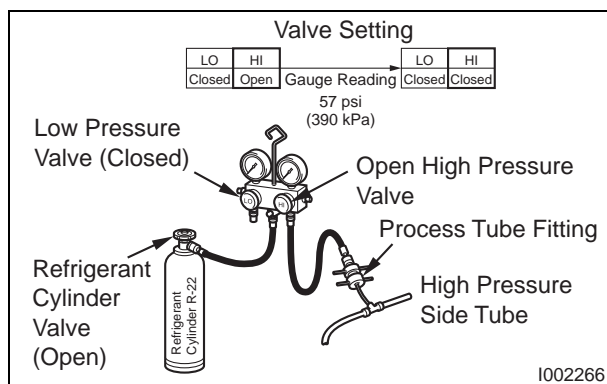
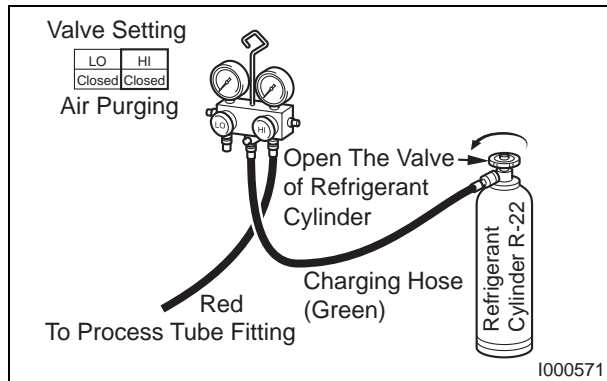

- 1) Remove the charging hose (green) from the vacuum pump, and connect the hose to the refrigerant cylinder (R-22).
- 2) Loosen the nut on the gauge manifold side of the charging hose (green).
- 3) Open the valve of refrigerant cylinder perform air purging in the charging hose (green). Then tighten the nut.
- 4) Open the high pressure valve of the gauge manifold. Charge the system with refrigerant until the low pressure gauge indicates 57 psi (0.39 kPa). After charging is complete, close the high pressure valve.
- 5) Open the valve of refrigerant cylinder perform air purging in the charging hose (green). Then tighten the nut.
- 6) Check carefully for gas leaks inside the refrigerant system using the gas leak tester.
- 7) Repair any leak.

⚠ WARNING

Do not attempt any repair on a charged system.

⚠ WARNING

Before checking for gas leaks, fully confirm that there is nothing flammable in the area to cause an explosion or fire. Contact of refrigerant with an open fire generates toxic gas.

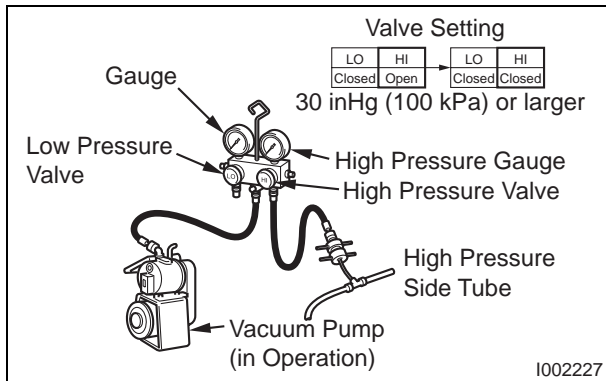
(5) Evacuation (repeat)

- 1) Close the valve of the refrigerant cylinder. Then remove the charging hose (green) from the refrigerant cylinder, and connect it to the refrigerant recovery machine.

< NOTE >

Keep the high pressure valve and the low pressure valve of the gauge manifold closed.

- 2) Using procedure in the “Evacuation”, evacuate the system until the low pressure gauge indicates 30inHg (100 kPa) or larger. (For 15 min or more.)
- 3) After evacuation is complete, close the high and the low pressure valves of the gauge manifold.

⚠ CAUTION

Make sure to evacuate the system twice or more using the repetitive vacuum method. Evacuate the system an additional time on rainy or humid days.

9.4 Refrigerant Charging Work

(1) Refrigerant charging

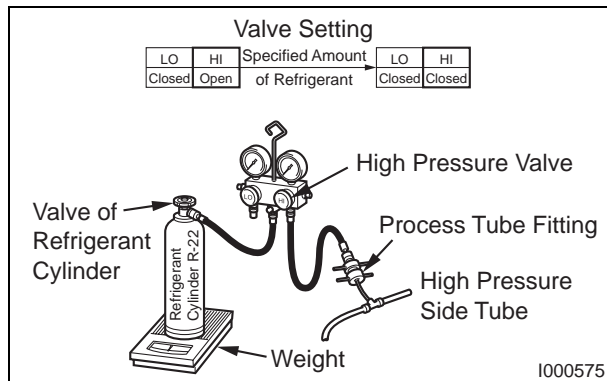
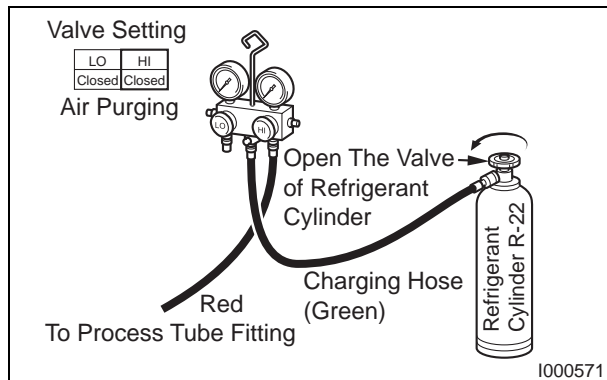

- 1) Remove the charging hose (green) from the vacuum pump, and connect it to the refrigerant cylinder (R-22).
- 2) Loosen the nut on the gauge manifold side of the charging hose (green). Open the valve of the charging hose (green). Open the valve of the refrigerant cylinder. After air purging, tighten this nut and close the valve of the refrigerant cylinder.
- 3) Securely place the refrigerant cylinder on a scale with a weighing capacity of 70 lb (30 kg) that is graduated by 0.2 oz (5 g).
- 4) Open the high pressure valve of the gauge manifold and the valve of the refrigerant cylinder. Charge the system with refrigerant to the specified amount.

Standard Amount of Refrigerant: 1.87 lb (850 g)

CAUTION

The amount of refrigerant charged has a great effect on the cooling capacity of the unit. Charge to the specified amount, always observing the scale graduations while charging.

- 5) Close the high pressure valve of the gauge manifold and the valve of the refrigerant cylinder.

(2) Removal of gauge manifold

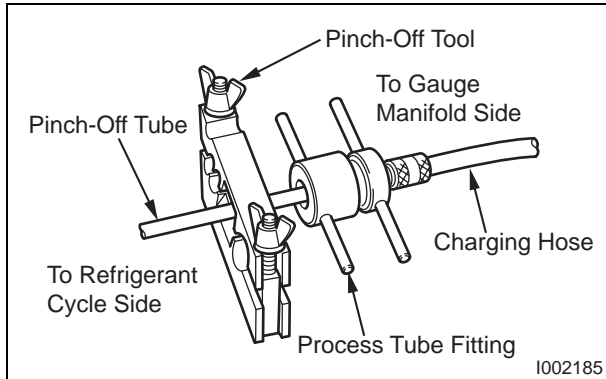

- 1) Crimp the pinch-off tube with a pinch-off tool.
- 2) Remove the gauge manifold and the process tube fitting. Crush the end of the pinch-off tube.
- 3) Braze the end of the pinch-off tube.
- 4) Ensure that a gas leak is not present at the pinched off portion and the brazed end.

10. REASSEMBLY

10.1 Removal of Unit

- Reassemble the unit in the reverse order of removal. Described below are the parts that require special care in reassembling the unit. Perform all wiring or rewiring as referenced in the wiring diagram.

10.2 Compressor Mounting

- Mount the compressor on the frame, using cushions, steel collars, spring washers, plate washers and nuts.

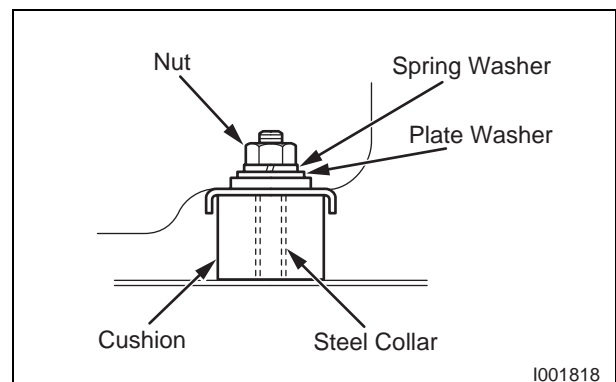

10.3 Blower Assembly

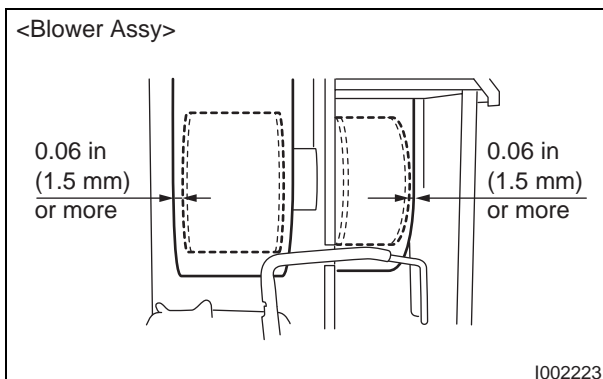

- Install blower fan for evaporator and blower fan for condenser. Allow a clearance of 0.06 in (1.5 mm) or more on each side of the evaporator fan and the condenser fan.

CAUTION

- Tightening torque:
- 10.84 ± 2.17 ft•lbf (15 ± 2.7 N•m)

10.4 Wiring Notice

- Secure the wires using clamps so that they do not come into contact with the edges of the structure, etc. Secure the wires using clamps in the same position they were before removal.

10.5 Perform the Inspection

- Perform the inspection of cooling performance and check for abnormal noise or abnormal vibration.

10.6 Caster Maintenance

- Lubricate bearings in caster as needed with standard bearing grease using the zerk fitting.

< NOTE >

Casters should roll and swivel freely. Check for dirt or dust build up. Remove dust or dirt build up.

10.7 Schematic

<Wiring Diagram>

AC 208/230 V 1ϕ 60 Hz

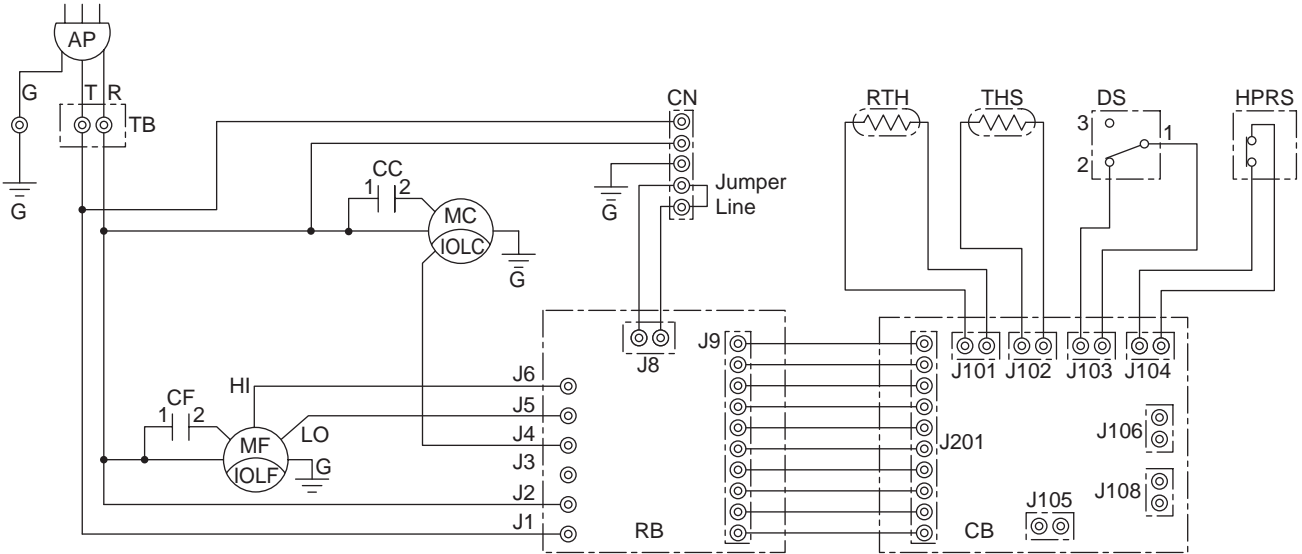

A	P	Attachment Plug
T	B	Terminal Block
C	B	Control Board
R	B	Relay Board
M	F	Fan Motor
M	C	Compressor Motor
C	F	Capacitor for Fan Motor
C	C	Capacitor for Compressor

I	O	L	F	Inner Overload Relay of Fan Motor
I	O	L	C	Inner Overload Relay of Compressor
D	S			Full Drain Warning Switch
T	H	S	Freeze Protection Thermistor	
R	T	H	Room Thermistor	
G	Grounding			
H	P	R	S	High Pressure Switch
C	N	Connector for Option Drain Pump		

DENSO

DENSO SALES CALIFORNIA, INC.

Long Beach, CA 90810

www.movincool.com