

Classic Plus 14

Cooling Capacity	Btu/hr. @ 95° At 60% Relative Humidity	13,200
Dimensions	Width (Inches) Depth (Inches) Height (Inches) Weight (Pounds) Shipping Weight	19 26 41 153 195
Electrical Characteristics	Power Supply (Volts) Power Consumption (Kilowatts) Current Consumption (Amperes) Fuse Size (Amperes) NEMA Plug Configuration Min-max Voltage Power Cord Gauge Power Cord Length (Feet)	115 1phase 1.3 12.3 15 5-15 105-125 Volt 14AWG (3 Core) 10
Compressor Characteristics	Compressor Type Refrigerant Operating Conditions: Min-max °F	Hermetic Rotary 22/410A 70°-113°F, 50% RH
Fan Characteristics	Evaporator: Fan Type Air Flow (CFM) High/Low Max. External Static (Inches Of Water Gauge) Condenser: Fan Type Air Flow (CFM) High/Low Max. External Static (Inches Of Water Gauge)	Centrifugal 440/380 0.31 Centrifugal 880/760 0.19
Safety Devices	Compressor Overload Relay Fan Motor Protection Anti-freeze Thermostat Automatic Tank Shut-off Condensate Tank Capacity (Gallons) High-pressure Switch Compressor Short-cycle Protection Fan Mode Switch Automatic Restart Thermostat Control Panel Thermostat Control	Yes Yes Yes Yes 5 N/A Yes Yes Yes Yes Yes Electronic Electronic
Miscellaneous Features	Operating Cost Humidity Removed @ 60% RH Accommodates Condensate Pump Sound Level (Db) High/Low Max Evaporator Ducting Length*(Ft.) Max Condenser Ducting Length*(Ft.)	\$0.093 0.69 Yes 57/55 30 60

**subtract 10 Ft. For Every 90° Bend*

800.367.8675 • www.spot-coolers.com

Copyright © 2008 Spot Coolers, Inc. All rights reserved.

Classic Plus 14

Power Supply 115 volts 60 hertz 1 phase 12.3 amperes

Width 19 inches

Depth 26 inches

Height 41 inches

Weight (net/shipping) lbs 153/195

All models are backed by a 12-month warranty with 36 months for the compressor.
All coils are treated with an acrylic resin coating for extended life and corrosion resistance.

TOP

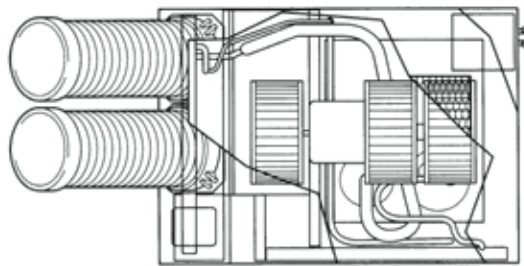

FRONT

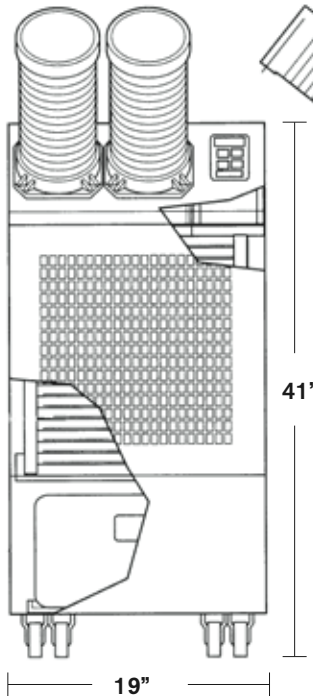

SIDE

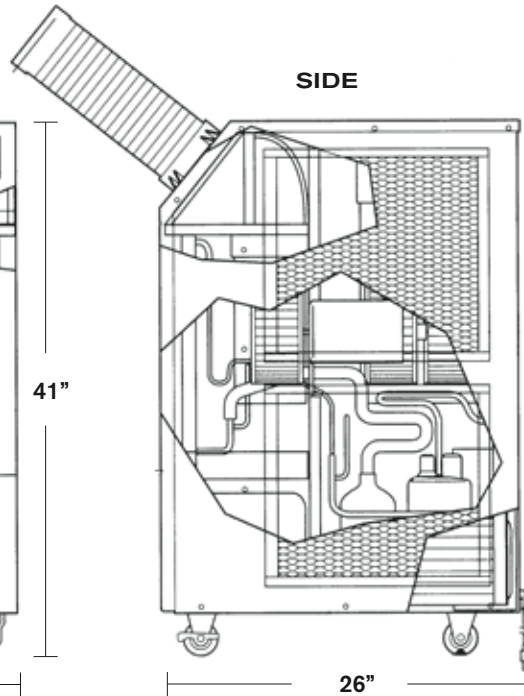

800.367.8675 • www.spot-coolers.com

Copyright © 2008 Spot Coolers, Inc. All rights reserved.

SPOT COOLERS

Classic Plus 14

Accessories

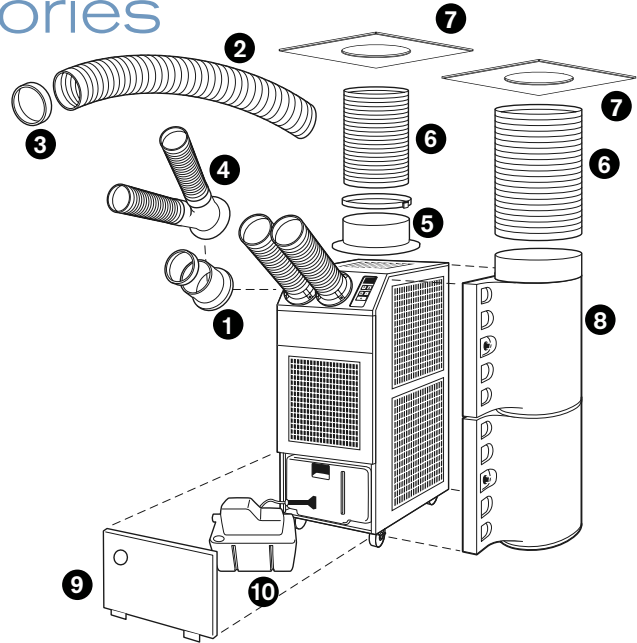
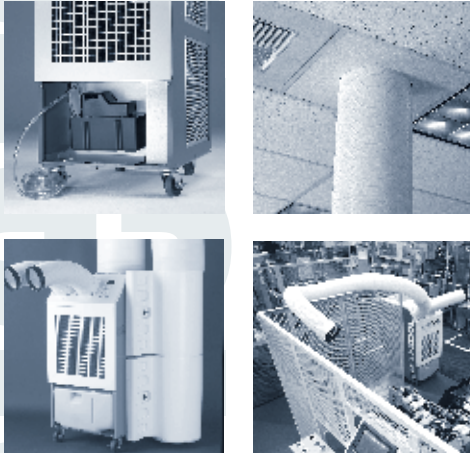

AUTO CONDENSATE REMOVAL

Why bother with emptying the drain tank when you can install a condensate pump to remove the water automatically! This pump has an 18-foot lift capacity to reach virtually any remote drain.

CONDENSER AIR REMOVAL

To exhaust the warm condenser air above the work area, attach the warm air flange and duct to the top of the unit. When inside an office, simply replace the ceiling tile with the unit ceiling tile and exhaust the warm air. No special tools or equipment are required for the installation.

MAKE-UP AIR

When balanced air flow is required, attach the air plenum with a duct from the side of the unit to an outside air source. The air to the condenser is pulled from outside the room to eliminate problems associated with negative air pressure.

SPOT or REMOTE COOLING

The amount of air supplied to remote areas can be quickly and conveniently increased by attaching 10' extension ducts directly over the standard ducts. For more permanent installations, use the flange and clamp to secure the extensions ducts to the unit.

PART NAME

CLASSIC PLUS 14

Cover Plate CP14-9
Blue metal plate covers condensate collection area.

Condensate Pump Kit CP14-10
110V pump kit includes 3/8" diameter x 20' length hose and installation hardware.

Warm Air Flange Kit CP14-5
12" diameter gray metal flange with wire clamp and mounting screws.

Warm Air Duct CP14-6
12" diameter white plastic duct extends 7' in length.

Ceiling Tile CP14-7
24" x 24" white tile with 12" hole for warm air duct.

Air Duct CP14-6
12" diameter white plastic duct extends 7' in length.

Ceiling Tile CP14-7
24" x 24" white tile with 12" hole for warm air duct.

Air Plenum CP14-8
White plastic plenum, hinged for filter cleaning.

Cold Air Flange Kit CP14-1
5" diameter gray metal flange with wire clamp and mounting screws.

Extension Duct CP14-2
5" diameter white plastic duct that extends from 6.5' to 10' in length.

Trim Ring CP14-3
5" diameter black plastic ring mounts as end caps for extension ducts.

Dual Duct CP14-4
5" diameter white plastic flange with two 4" nozzles that extend to 3.5' in length.

Classic Plus 14

Construction Diagram

All models are backed by a 12-month warranty with 36 months for the compressor.

All coils are treated with an acrylic resin coating for extended life and corrosion resistance.

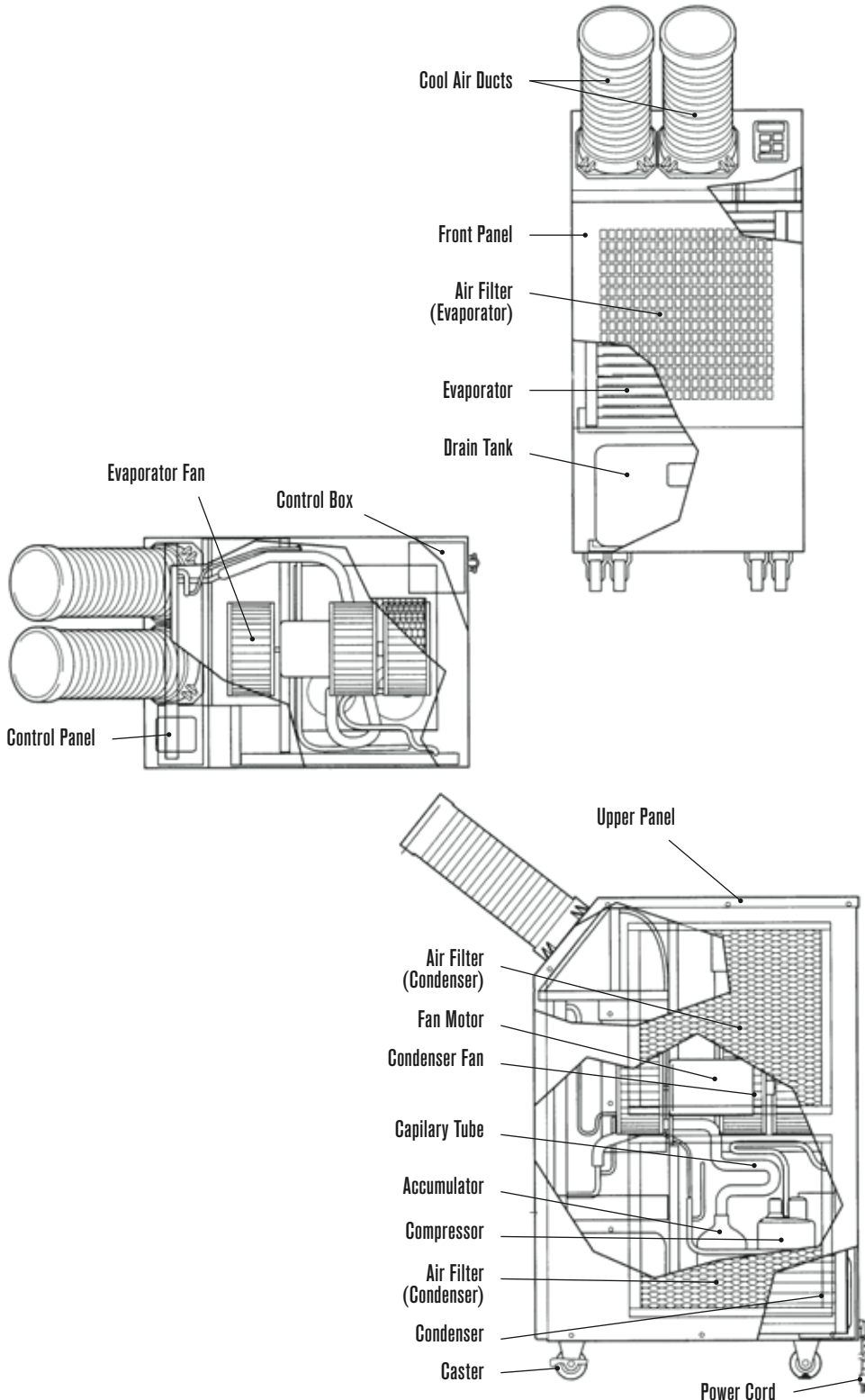

SPOT COOLERS